



## ABA

naváňovací bod, pevný

- ABA slouží ke zvedání a manipulaci s břemeny
- **Nosnosti 0,8 t až 31,5 t** (viz tabulka nosností)
- Plně zatížitelný ve všech směrech
- Kovaný vázací bod, odolný proti opotřebení
- Indikátory opotřebení na vnějším i vnitřním obvodu
- Fosfátovaný povrch
- Bezpečnostní faktor 4:1
- Max. rozsah teplotního zatížení
  - bez redukce nosnosti -40° až 200°C
- Max. rozsah teplotního zatížení
  - s redukcí nosnosti až 400°C















# PAVLÍNEK®

## VÁZACÍ PROSTŘEDKY

Tabulka nosností v tunách – ABA

Typ	0,8 t	1,6 t	3,2 t	5 t	10 t	20 t	31,5 t
<b>Počet pramenů / úhel Beta</b>	<b>a 3</b> ▽	<b>a 4</b> ▽	<b>a 6</b> ▽	<b>a 7</b> ▽	<b>a 8</b> ▽	<b>a 12</b> ▽	<b>a 15</b> ▽
 1	0,8	4	9	12	20	20	31,5
 2	1,6	8	18	24	40	40	63
 1	0,8	1,6	3,2	5	10	20	31,5
 2	1,6	3,2	6,4	10	20	40	63
 2	1,1	5,6	12,6	16,8	28	28	45
 2	0,8	4	9	12	20	20	31,5
 2	0,8	4	9	12	20	20	31,5
 3+4	1,7	3,4	6,8	10,6	21,2	42	67
 3+4	1,2	2,4	4,8	7,5	15	30	47,5
 3+4	0,8	1,6	3,2	5	10	20	31,5



EMAIL: [OBCHOD@PAVLINEK.CZ](mailto:OBCHOD@PAVLINEK.CZ)  
 TEL: +420 595 693 911  
 ŠALOUNOVA 746/31, OSTRAVA VÍTKOVICE  
 IČ: 25358511 DIČ: CZ25358511



# PAVLÍNEK®

## VÁZACÍ PROSTŘEDKY

EMAIL: [OBCHOD@PAVLINEK.CZ](mailto:OBCHOD@PAVLINEK.CZ)  
 TEL: +420 595 693 911  
 ŠALOUNOVA 746/31, OSTRAVA VÍTKOVICE  
 IČ: 25358511 DIČ: CZ25358511





# PAVLÍNEK® VÁZACÍ PROSTŘEDKY

Tabulka rozměrů ABA

Typ	WLL [t]	Hmotnost [kg/ks]	T [mm]	A [mm]	B [mm]	C [mm]	D [mm]	E [mm]	F [mm]	Svár
ABA.0,8	0,8	0,2	32	22	12	70	32	12	50	a 3
ABA.1,6	1,6	0,45	42	30	16	100	35	16	57	a 4
ABA.3,2	3,2	1,15	59	41	23	137	50	21	80	a 6
ABA.5	5	2,26	72	51	27	172	60	28	99	a 7
ABA.10	10	5,37	95	70	38	228	80	35	130	a 8
ABA.20	20	10,72	135	90	52	272	115	40	175	a 12
ABA.31,5	31,5	18,33	154	108	64	320	130	50	204	a 15



EMAIL: [OBCHOD@PAVLINEK.CZ](mailto:OBCHOD@PAVLINEK.CZ)  
TEL: + 4 2 0 5 9 5 6 9 3 9 1 1  
ŠALOUNOVA 746/31, OSTRAVA VÍTKOVICE  
IČ: 25358511 DIČ: CZ25358511

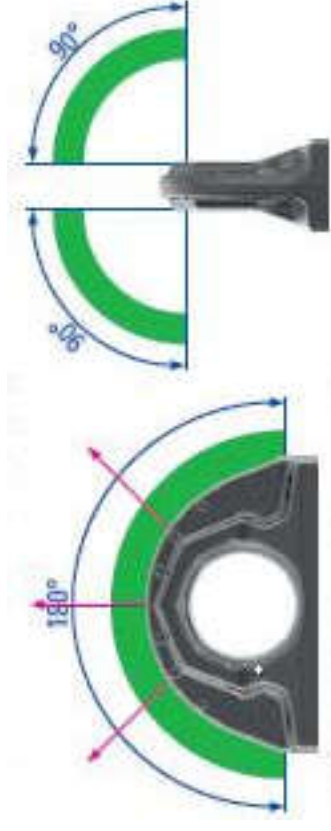
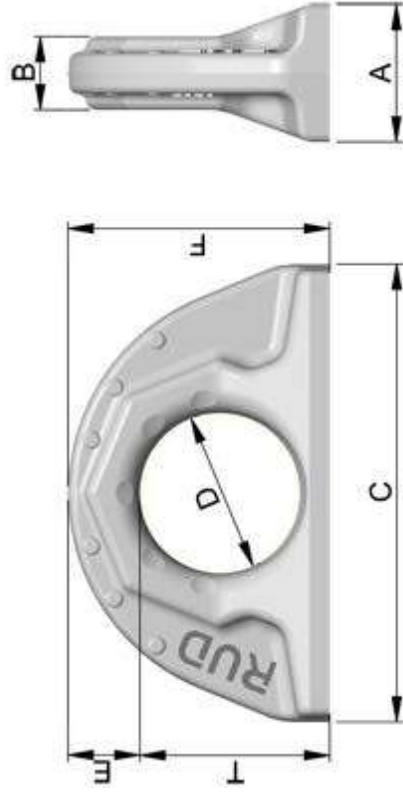

# PAVLÍNEK® VÁZACÍ PROSTŘEDKY

EMAIL: [OBCHOD@PAVLINEK.CZ](mailto:OBCHOD@PAVLINEK.CZ)  
TEL: + 4 2 0 5 9 5 6 9 3 9 1 1  
ŠALOUNOVA 746/31, OSTRAVA VÍTKOVICE  
IČ: 25358511 DIČ: CZ25358511

