

# Excavator hook - for welding - **VCGH-S**



Excavator hook - for welding  
**VCGH-S**

## Safety instructions

This safety instruction/declaration of the manufacturer has to be kept on file for the whole lifetime of the product.  
Translation of the Original instructions



RUD Ketten  
Rieger & Dietz GmbH u. Co. KG

-Nir.: 8502510-EN / 04.016



**PAVLÍNEK**<sup>®</sup>  
VÁZACÍ PROSTŘEDKY

**EMAIL: OBCHOD@PAVLINEK.CZ**  
**TEL: +420 595 693 911**  
**ŠALOUNOVA 746/31, OSTRAVA VÍTKOVICE**  
**IČ: 25358511 DIČ: CZ25358511**



### EC-Declaration of conformity

According to the EC-Machinery Directive 2006/42/EC, annex II A and amendments

Manufacturer: **RUD Ketten**  
**Rieger & Dietz GmbH u. Co. KG**  
Friedensinsel  
73432 Aalen

We hereby declare that the equipment sold by us because of its design and construction, as mentioned below, corresponds to the appropriate, basic requirements of safety and health of the corresponding EC-Machinery Directive 2006/42/EC as well as to the below mentioned harmonized and national norms as well as technical specifications.  
In case of any modification of the equipment, not being agreed upon with us, this declaration becomes invalid.

**Product name:** Bolt on / Weld on hook  
VABH-B / VABH-W / VCGH-G / VCGH-S

The following harmonized norms were applied:  
DIN EN 1677-1 : 2009-03      DIN EN ISO 12100 : 2011-03  
\_\_\_\_\_  
\_\_\_\_\_  
\_\_\_\_\_

The following national norms and technical specifications were applied:  
BGR 500, KAP2.8 : 2008-04      DIN 15428 : 1978-08  
\_\_\_\_\_  
\_\_\_\_\_  
\_\_\_\_\_

Authorized person for the configuration of the declaration documents:  
Reinhard Smetz, RUD Ketten, 73432 Aalen

Aalen, den 27.06.2014      Dr.-Ing. Arne Kriegsmann, (Prokurist/QMB) *Arne Kriegsmann*  
Name, function and signature of the responsible person

### EG-Konformitätserklärung

entsprechend der EG-Maschinenrichtlinie 2006/42/EG, Anhang II A und ihren Änderungen

Hersteller: **RUD Ketten**  
**Rieger & Dietz GmbH u. Co. KG**  
Friedensinsel  
73432 Aalen

Hiermit erklären wir, dass die nachfolgend bezeichnete Maschine aufgrund ihrer Konzipierung und Bauart, sowie in der von uns in Verkehr gebrachten Ausführung, den grundlegenden Sicherheits- und Gesundheitsanforderungen der EG-Maschinenrichtlinie 2006/42/EG sowie den unten aufgeführten harmonisierten und nationalen Normen sowie technischen Spezifikationen entspricht.  
Bei einer nicht mit uns abgestimmten Änderung der Maschine verliert diese Erklärung ihre Gültigkeit.

**Produktbezeichnung:** Anbauhaken  
VABH-B / VABH-W / VCGH-G / VCGH-S

Folgende harmonisierten Normen wurden angewandt:  
DIN EN 1677-1 : 2009-03      DIN EN ISO 12100 : 2011-03  
\_\_\_\_\_  
\_\_\_\_\_  
\_\_\_\_\_

Folgende nationalen Normen und technische Spezifikationen wurden außerdem angewandt:  
BGR 500, KAP2.8 : 2008-04      DIN 15428 : 1978-08  
\_\_\_\_\_  
\_\_\_\_\_  
\_\_\_\_\_

Für die Zusammenstellung der Konformitätsdokumentation bevollmächtigte Person:  
Reinhard Smetz, RUD Ketten, 73432 Aalen

Aalen, den 27.06.2014      Dr.-Ing. Arne Kriegsmann, (Prokurist/QMB) *Arne Kriegsmann*  
Name, Funktion und Unterschrift Verantwortlicher

## User Instructions

1. Reference should be made to German Standards according BGR 500 (DGUV rules 100-500) or other country specific statutory regulations and inspections are to be carried out by competent persons only.

2. Before installing and every use, visually inspect RUD lifting points, paying particular attention to any evidence of weld cracks, corrosion, wear, deformations, etc.

3. The material construction to which the lifting point will be attached should be of adequate strength to withstand forces during lifting without deformation. The contact areas must be free from impurities, oil, colour, ect.

The Material of the welding plate is S355J2G3 (1.0577+N (St52-3)).

4. The lifting points must be positioned on the load in such a way that movement is avoided during lifting.

a.) For single leg lifts, the lifting point should be vertically above the centre of gravity of the load.

b.) For two leg lifts, the lifting points must be equidistant to/or above the centre of gravity of the load.

c.) For three and four leg lifts, the lifting points should be arranged symmetrically around the centre of gravity in the same plane.

### 5. Load Symmetry:

The working load limits of individual RUD lifting points are calculated using the following formula and are based on symmetrical loading:

$$W_{LL} = \frac{G}{n \times \cos \beta}$$

$W_{LL}$  = working load limit  
 $G$  = load weight (kg)  
 $n$  = number of load bearing legs  
 $\beta$  = angle of inclination of the chain to the vertical

The calculation of load bearing legs is as follows:

	symmetrical	asymmetrical
two leg	2	1
three / four leg	3	1

(see table 1)

6. The installation should be in the direction of pull.

Possible use area:

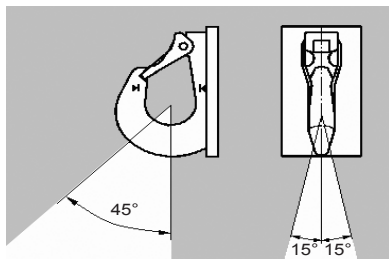

7. All fittings connected to the VCGH-S should be free moving. When connecting and disconnecting the lifting means (sling chain), pinches and impacts should be avoided. Damage of the lifting means caused by sharp edges should be avoided as well.

### 8. Effect of temperatur:

During use in overheated areas the WLL of the VCGH-S has to be reduced according the chart:

-20° up to 200°C	no reduction
200° up to 300°C minus 10 %	(392°F up to 572°F)
300° up to 400°C minus 25 %	(572°F up to 752°F)

Temperatures above 400°C (752°F) are not allowed.

9. The places where the lifting points are fixed should be marked with colour.

10. RUD-Lifting points must not be used under chemical influences such as acids, alkaline solutions and vapours e.g. in pickling baths or hot dip galvanising plants. If this cannot be avoided, please contact the manufacturer indicating the concentration, period of penetration and temperature of use.

11. If the lifting points are used **exclusively** for lashing the value of the working load limit can be doubled.  $LC = 2 \times WLL$

12. After welding, an annual inspection or sooner if conditions dictate should be undertaken by a competent person examining the continued suitability. Also after damage and special occurrences.

### Inspection criteria concerning paragraphs 2 and 12:

- The lifting point should be complete.
- The working load limit and manufacturers stamp should be clearly visible.
- Deformation of the component parts such as body.
- Mechanical damage, such as notches, particularly in high stress areas.
- Wear should be no more than 10 % of cross sectional diameter.
- Evidence of corrosion.
- Evidence of cracks.
- Cracks or other damages to the welding.

*A non-adherence to this advice may result damages of persons and materials!*

Method of lift								
Number of legs	1	2	2	2	3 and 4	3 and 4	3 and 4	
Angle of inclination <math>\beta</math>	90°	90°	0-45°	45-60°	unsymm.	0-45°	45-60°	unsymm.
Factor	1	2	1,4	1	1	2,1	1,5	1
<b>type</b>	<b>WLL (total weight) in tonnes</b>							
VCGH-S 6 *	1,5 t 3300 lbs	3 t 6600 lbs	2,1 t 4620 lbs	1,5 t 3300 lbs	1,5 t 3300 lbs	3,15 t 6930 lbs	2,25 t 4950 lbs	1,5 t 3300 lbs
VCGH-S 8 *	2,5 t 5500 lbs	5 t 11000 lbs	3,5 t 7700 lbs	2,5 t 5500 lbs	2,5 t 5500 lbs	5,25 t 11550 lbs	3,75 t 8250 lbs	2,5 t 5500 lbs
VCGH-S 10 *	4 t 8800 lbs	8 t 17600 lbs	5,6 t 12300 lbs	4 t 8800 lbs	4 t 8800 lbs	8,4 t 18500 lbs	6 t 13200 lbs	4 t 8800 lbs
VCGH-S 13 *	6,5 t 14300 lbs	13 t 28600 lbs	9,1 t 20000 lbs	6,5 t 14300 lbs	6,5 t 14300 lbs	13,65 t 30000 lbs	9,75 t 21450 lbs	6,5 t 14300 lbs
VCGH-S 16	10 t 22000 lbs	20 t 44000 lbs	14 t 30800 lbs	10 t 22000 lbs	10 t 22000 lbs	21 t 46200 lbs	15 t 33000 lbs	10 t 22000 lbs
VCGH-S 20	16 t 35200 lbs	32 t 70400 lbs	22,4 t 49300 lbs	16 t 35200 lbs	16 t 35200 lbs	33,6 t 74000 lbs	24 t 52800 lbs	16 t 35200 lbs
VCGH-S 22	20 t 44000 lbs	40 t 88000 lbs	28 t 61600 lbs	20 t 44000 lbs	20 t 44000 lbs	42 t 92400 lbs	30 t 66000 lbs	20 t 44000 lbs



Ta



**PAVLÍNEK**  
VÁZACÍ PROSTŘEDKY

EMAIL: [OBCHOD@PAVLINEK.CZ](mailto:OBCHOD@PAVLINEK.CZ)  
TEL: +420 595 693 911  
ŠALOUNOVA 746/31, OSTRAVA VÍTKOVICE  
IČ: 25358511 DIČ: CZ25358511



\* are replaced by type VABH-W

The welding should only be carried out according to EN 287 or AWS Standards by an authorized welder.

### Welding sequence:

- Tack Weld at the right position. Before carrying out the top run, carefully clean the root.
- The welding process must not be interrupted for such a time that the welding plate loses the welding temperature
- The fillet welding process had to be carried out circulated

Welding beam			
	size	length	volume
VCGH-S 6	a = 5	247 mm	ca. 8,3 cm <sup>3</sup>
VCGH-S 8	a = 5	352 mm	ca. 10,6 cm <sup>3</sup>
VCGH-S 10	a = 6	410 mm	ca. 17,5 cm <sup>3</sup>
VCGH-S 13	a = 8	490 mm	ca. 36,7 cm <sup>3</sup>
VCGH-S 16	a = 8	580 mm	ca. 42,5 cm <sup>3</sup>
VCGH-S 20	a = 8	750 mm	ca. 52 cm <sup>3</sup>
VCGH-S 22	a = 8	770 mm	ca. 56 cm <sup>3</sup>

Tabelle 3



**PAVLÍNEK**<sup>®</sup>  
VÁZACÍ PROSTŘEDKY

EMAIL: [OBCHOD@PAVLINEK.CZ](mailto:OBCHOD@PAVLINEK.CZ)  
TEL: +420 595 693 911  
ŠALOUNOVA 746/31, OSTRAVA VÍTKOVICE  
IČ: 25358511 DIČ: CZ25358511



### Welding procedure + Welding filler metals:

	Europa (DE, GB, FR, ....)	USA, Canada, ..
	structural steel Low alloyed steel	
pulsed MIG arc welding MAG	ISO 14341: G4 Si 1 z.B. Castolin 45250	ISO 14341: G4 Si 1 AWS A 5.18 : ER 70 S-6 z.B. Eutectic MIG-Tec Tic A88
electric manual DC =	EN ISO 2560-A - E 42 6 B 3 2; EN ISO 2560-A - E 38 2 B 12 H10 z.B. Castolin 6666 * Castolin 6666 N*	AWS A 5.5 : E 8018-G AWS A 5.5 : E 7016 EN ISO 2560-A - E 42 6 B 3 2; EN ISO 2560-A - E 38 2 B 12 H10 z.B. Eutectic 6666/ 35066 CP *
electric manual AC ~	EN ISO 2560-A - E 38 0 RR 1 2 EN ISO 2560-A - E 42 0 RR 1 2; z.B. Castolin 6600 Castolin 35086 no-load-voltage 35-48 (max.) V	AWS A 5.1 : E 6013 EN ISO 2560-A - E 38 0 RR 1 2 EN ISO 2560-A - E 42 0 RR 1 2; z.B. Eutectic Beauty Weld II
TIG (tungsten inert-gas shielded) welding	ISO 636: W3 Si 1 z.B. Castolin 45255W	ISO 636: W3 Si 1 AWS A 5.18 : ER 70 S-6 z.B. Eutectic TIG-Tec-Tic: A 88

Table 2

\* Follow the drying instructions!

The specific processing informations of the welding fillers have to be attended.

Subject to technical alternations

### Welding seam definition:

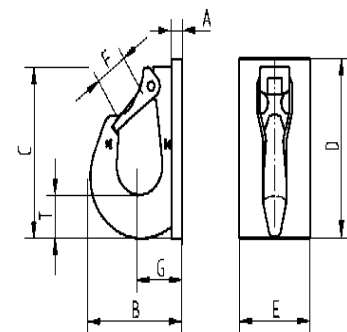
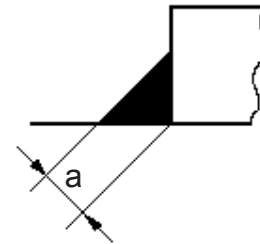

Type	WLL t	weight kg	A	B	C	D	E	F	G	Welding beam a	ref-no.	Safety set
VCGH-S 6 *	1,5	0,6	10	68	97	100	60	25	37	5	*	7100299
VCGH-S 8 *	2,5	1,4	10	84	126	135	70	30	41	5	*	7100300
VCGH-S 10 *	4	1,9	12	106	148	155	80	35	50	6	*	7100301
VCGH-S 13 *	6,5	3,3	15	120	170	185	90	40	60	8	*	7100302
VCGH-S 16	10	5,0	15	141	200	220	100	48	70	8	<b>7984047</b>	7100303
VCGH-S 20	16	8,4	20	187	272	288	120	63	87	8	<b>7984310</b>	7101604
VCGH-S 22	20	15,4	20	196	276	292	120	63	92	8	<b>7984312</b>	7101604

Table 4

\* are replaced by type VABH-W