



Original Instruction

**OWNER'S (OPERATOR'S) MANUAL
AND SAFETY INSTRUCTIONS
FOR KITO MANUAL CHAIN HOIST**

M3 SERIES

ALWAYS SAVE THIS BOOK FOR FUTURE REFERENCE.

KITO

Issued September 1994. Revised March, 2022 (revision 13)

CONTENTS

1. DEFINITIONS	1
2. INTENDED PURPOSE	1
3. MOUNTING	1
4. BEFORE USE	1
4.1 Safety summary	1
4.2 Safety instructions	2
5. MAIN SPECIFICATIONS	5
6. OPERATION	7
6.1 Intended purpose of hoist operation	7
6.2 Safety working environment	7
6.3 Operation	7
6.4 Hoist storage	7
6.5 Optional overload limiter	8
7. INSPECTION	9
7.1 Outline	9
7.2 Daily inspection	9
7.3 Periodic inspection	10
8. MAINTENANCE AND STORAGE	15
8.1 Lubrication	15
8.2 Overhaul, assembly and adjustment	16
9. TROUBLESHOOTING	25
10. WARRANTY	26
11. PARTS LIST	27
12. CONTENTS OF EC DECLARATION OF CONFORMITY	33

1. DEFINITIONS

⚠ WARNING : Indicates a potentially hazardous situation which, if not avoided, could result in death or serious injury.

⚠ CAUTION : Indicates a potentially hazardous situation which, if not avoided, may result in minor or moderate injury. It may also be used to alert against unsafe practices.

WLL: Indicates maximum mass (working load limit) which a hoist is designed to support in general service.

2. INTENDED PURPOSE

This hoist has been designed for vertically lifting and lowering loads, by hand, under normal atmospheric conditions of the work place.

3. MOUNTING

Before mounting the hoist, fill in the following table with the opening dimension “c” between embossed marks on the top and bottom hook as records preparing for periodic inspection.

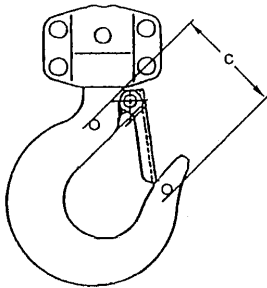

Dimension c	Top hook (if applicable)	mm
	Bottom hook	mm

⚠ WARNING

ALWAYS Avoid the following when mounting the chain hoist.
 Failure to comply with these instructions may result in death or severe injury.

- Ensure that only trained or competent persons install the chain hoist.
- Do not install the chain hoist within the range of movement of other devices (equipment), such as a trolley.

ALWAYS Comply with the following instructions when installing the chain hoist.
 Failure to comply with these instructions may result in death or severe injury.

- The safety factor of the manual chain hoist is 4:1. The hoist may lift and hold a load more than the rated load check that the structure for mounting the chain hoist has sufficient strength.
- Fix the Top Hook to the structure securely.
- Before using the chain hoist with a trolley, read the Instruction Manual of the trolley carefully and install it by adjusting the rail width.
- Install a stopper at both ends of the traversing rail for the trolley.

⚠ CAUTION

ALWAYS Comply with the following instructions when installing the chain hoist.
 Failure to comply with these instructions may result in injury or damage to property.

- Install the chain hoist at appropriate place avoiding obstacles.
- Install the Load Chain with sufficient length for lifting work.

4. BEFORE USE

4.1 Safety summary

Danger exists when heavy loads are transported, particularly when the equipment is not being used properly or is poorly maintained. Because accidents and serious injury could result, special safety precautions apply to the operation, maintenance and inspection of the KITO manual chain hoist M3 series.

⚠ WARNING

- NEVER** use a hoist for lifting, supporting or transporting people. -----
- NEVER** lift or transport loads over or near people. -----
- NEVER** lift more than WLL which is shown on the name plate. -----
- ALWAYS** let people around you know when a lift is about to begin. -----
- ALWAYS** read the operation and safety instructions. -----

Remember proper rigging and lifting techniques are the responsibility of the operator. Check all applicable safety codes, regulations and other applicable laws for further information about the safe use of your hoist.

More detailed safety information is contained in the following pages. For additional information, please contact KITO Corporation or your authorized KITO dealer.

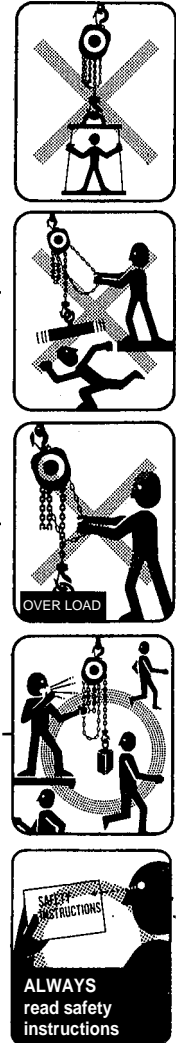

4.2 Safety instructions

⚠ WARNING

4.2.1 Before use

- ALWAYS** be sure to wear the proper clothing and personal protective equipment when using and operating the product.
- ALWAYS** allow the instructed (trained in safety and operation) people to operate the hoist.
- ALWAYS** check the hoist before daily use according to the “Daily inspection” (Refer to 7.2).
- ALWAYS** make sure that the chain length is long enough for the intended job.

ALWAYS check that the hook latches work properly and replace missing or broken hook latches (Refer to 7.3).

ALWAYS check the brake (Refer to 7.3).

ALWAYS oil the load chain regularly (Refer to 8.1.2).

ALWAYS use two hoists which each has WLL equal to or more than the load to be lifted whenever you must use two hoists to lift a load. This will provide adequate protection in the event that a sudden load shift or failure of one hoist occurs.

NEVER use a hoist without a hoist name plate.

NEVER use modified or deformed hooks.

NEVER use non-authentic KITO chains on the hoist.

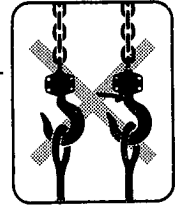

4.2.2 While operation

ALWAYS make sure that the load is properly seated in the hook.

ALWAYS tighten the slack out of the chain and sling when starting a lift to prevent a sudden loading.

ALWAYS when any abnormality is observed during the operation, stop the operation immediately, indicate "FAILURE" and contact with the maintenance engineers.

ALWAYS when inspecting and repairing, be sure to indicate "INSPECTION" and carry out without lifting a load.

NEVER operate a hoist unless the load is centered under the hoist.

NEVER use the hoist chain as a sling.

NEVER use a twisted, kinked, damaged or stretched load chain.

NEVER swing a suspended load.

NEVER support a load on the tip of the hook.

NEVER contact the load chain over an edge.

NEVER weld or cut a load suspended by a hoist.

NEVER use the hoist chain as a welding electrode.

NEVER operate a hoist so far that the bottom hook touches the hoist body.

NEVER operate a hoist so far that the load chain pulls the anchorage.

NEVER operate a hoist if excessive noise occurs.

NEVER use a capsized load chain.

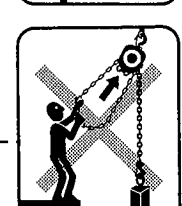
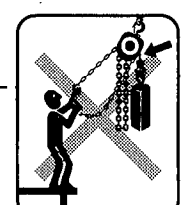
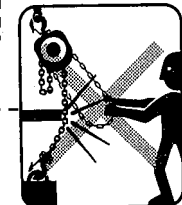
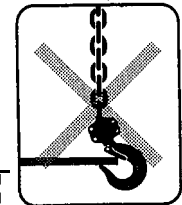
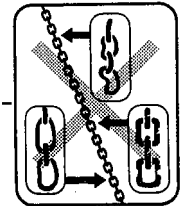

4.2.3 After operation

ALWAYS set the load down safely after carrying.

NEVER suspend a load for an extended period of time.

NEVER leave a suspended load unattended.

NEVER throw a hoist.

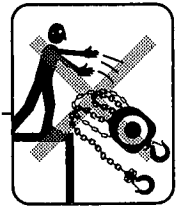

4.2.4 Maintenance

ALWAYS let the qualified service personnel inspect the hoist periodically (Refer to 7.3).

NEVER splice, add and weld a load chain for extension.

4.2.5 Others

ALWAYS consult the manufacturer or your dealer if you plan to use a hoist in an excessively corrosive environment (saltwater, sea air and/or acid, explosive environment or other corrosive compounds, etc.).

NEVER use a hoist which has been taken out of service until the hoist has been properly repaired or replaced.

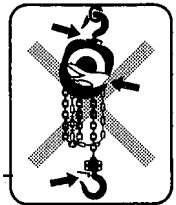

NEVER remove or obscure the warning tags and labels.

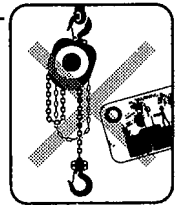

Warning tags are installed on the hand chain.

5. MAIN SPECIFICATIONS

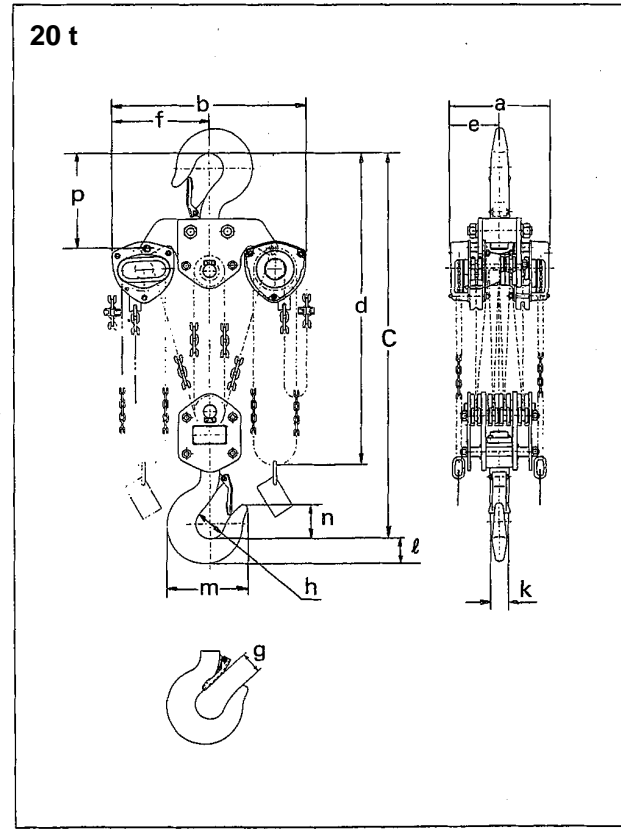
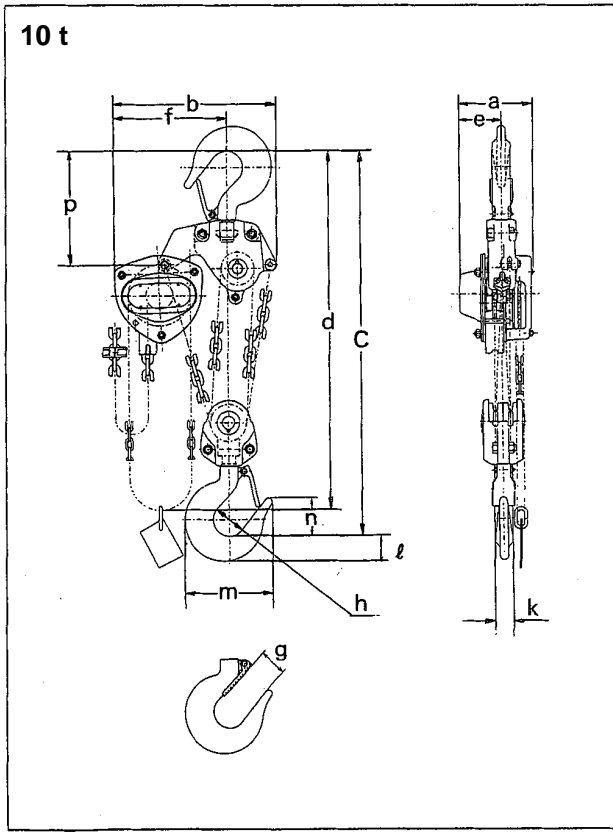
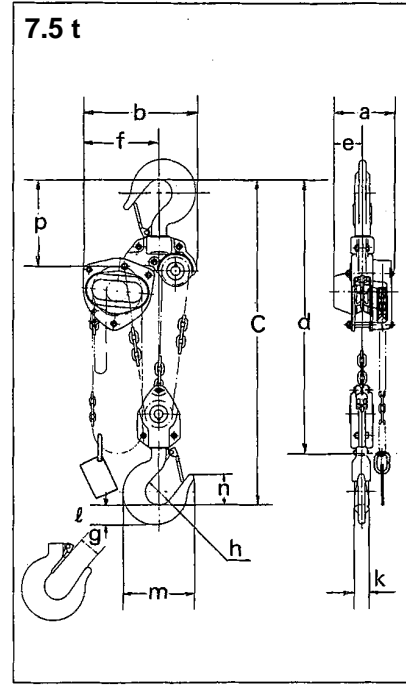
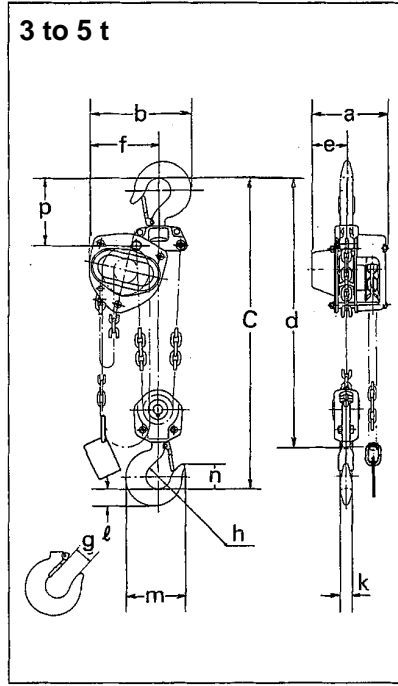
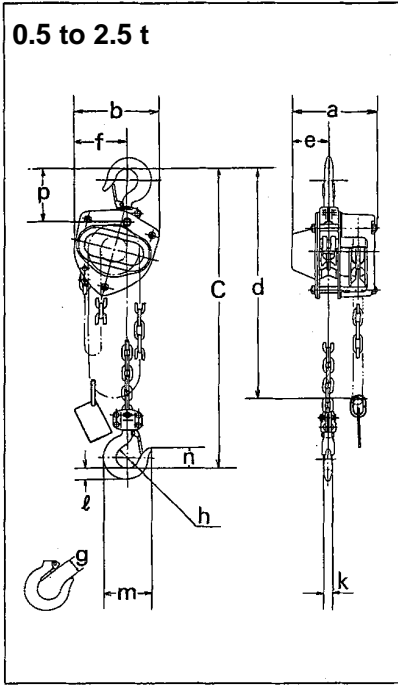

Specifications

Code	WLL (t)	Std. lift (m)	Chain pull to lift full load (N)	Hand chain length for 1m lifting* (m)	Test load (t)	Net weight (kg)	Load chain dia. (mm) x pitch (mm)	Load chain fall (lines)	Weight for additional one meter of lift (kg)
CB005	0.5	2.5	240	25	0.75	10	5.0 x 15.0	1	1.5
CB010	1	2.5	290	43	1.5	11.5	6.3 x 19.0	1	1.8
CB015	1.5	2.5	350	57	2.25	14.5	7.1 x 21.0	1	2.1
CB020	2	3.0	360	70	3	20	8.0 x 24.0	1	2.3
CB025	2.5	3.0	330	99	3.75	27	9.0 x 27.0	1	2.7
CB030	3	3.0	360	114	4.5	24	7.1 x 21.0	2	3.2
CB050	5	3.0	340	198	7.5	41	9.0 x 27.0	2	4.4
CB075	7.5	3.5	350	297	11.25	63	9.0 x 27.0	3	6.2
CB100	10	3.5	360	396	15	83	9.0 x 27.0	4	7.9
CB150	15	3.5	370	594	22.5	155	9.0 x 27.0	6	11.4
CB200	20	3.5	360 x 2	396 x 2	25	235	9.0 x 27.0	8	15.8

Remark: Any lift of chain is available on request.

*Length of the hand chain necessary to lift a load 1m.

This device was tested according to the required static and dynamic load test provided on the European standard EN13157.

Dimensions

Code	WLL (t)	Min. distance between hooks C (mm)	a (mm)	b (mm)	d (mm)	e (mm)	f (mm)	g (mm)	h (mm)	k (mm)	ℓ (mm)	m (mm)	n (mm)	p (mm)
CB005	0.5	285	158	161	2.5	69	99	27	35.5	12.1	17	77	35	89
CB010	1	295	162	161	2.5	71	99	29	42.5	16	21.8	93	11	101
CB015	1.5	350	171	182	2.5	78	112	34	47.5	19.5	26.5	106	47	119
CB020	2	375	182	202	3	87	125	36	50	21.8	30	116	49	124
CB025	2.5	420	192	233	3	91	143	40	53	24.3	33.5	127	53	136
CB030	3	510	171	235	3.1	78	162	42.5	56	27.2	37.5	138	57	148
CB050	5	600	192	282	3.6	91	194	46.5	63	34.5	47.5	161	67.5	172
CB075	7.5	770	192	373	4.2	91	253	72.5	85	47.5	63	231	97.5	275
CB100	10	760	192	438	4.2	111	308	72.5	85	47.5	63	231	97.5	295
CB150	15	1020	268	492	4.7	119	337	80	100	60	80	275	110	320
CB200	20	1180	374	746	4.8	187	373	81	110	67	90	301	125	351

Allowable ambient conditions:

Operation temperature: -40°C to +60°C

Operation humidity: 100%

Non-asbestos material:

Friction plates are made of asbestos free material.

6. OPERATION

6.1 Intended purpose of hoist operation

⚠ WARNING

This hoist has been designed for vertically lifting and lowering loads, by hand, under normal atmospheric conditions of the work place.

However, since dealing with heavy loads may involve unexpected danger, all the “Safety instructions” (Refer to 4.2) must be followed.

6.2 Safety working environment

⚠ WARNING

The operator must be aware of the following points while using the hoist.

- (1) The operator must have a clear and unobstructed view of the entire travel area before operating the hoist. When not possible, a second or more persons must serve as scouts in the nearby area.
- (2) The operator must check if the entire travel area is safe and secure before operating the hoist.

6.3 Operation

⚠ CAUTION

Always take care hand or clothes not to be caught in a chain, idle sheave or other moving parts.

- (1) Face the hand chain wheel side of the hoist.
- (2) To raise the load, pull hand chain clockwise.
- (3) To lower the load, pull hand chain counterclockwise.
- (4) There are risks of overheating of the breaking system during prolonged lowering of loads. If you are considering the use under such condition, consult KITO.

Remark: The clicking sound of the pawl when a load is being raised indicates normal operation.

6.4 Hoist storage

⚠ CAUTION

Observe the following points when storing the hoist.

- ALWAYS** store the hoist in no load condition.
- ALWAYS** wipe off all dirt and water.
- ALWAYS** oil the chain, top pin, chain pin and hook latches.
- ALWAYS** hang in a dry place.
- ALWAYS** check the hoist for abnormalities when using the hoist after a period of non-use according to the periodic inspection procedures (Refer to 7.3).

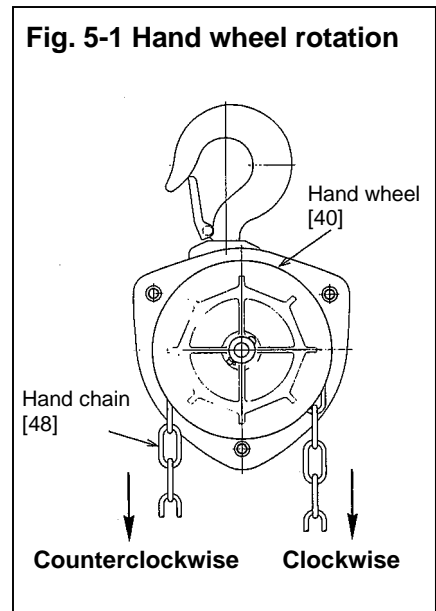

6.5 Optional overload limiter

⚠ WARNING

NEVER disassemble or attempt to adjust the overload limiter assembly. Any attempt to do so will void the warranty. Contact your KITO dealer, if service is required.

The overload limiter device has been developed to avoid overloading. When an applied load exceeds the preset value, the hand chain wheel rotates idly. The device is a friction clutch mechanism which is concentrically equipped on pinion shaft between hand chain wheel and mechanical brake.

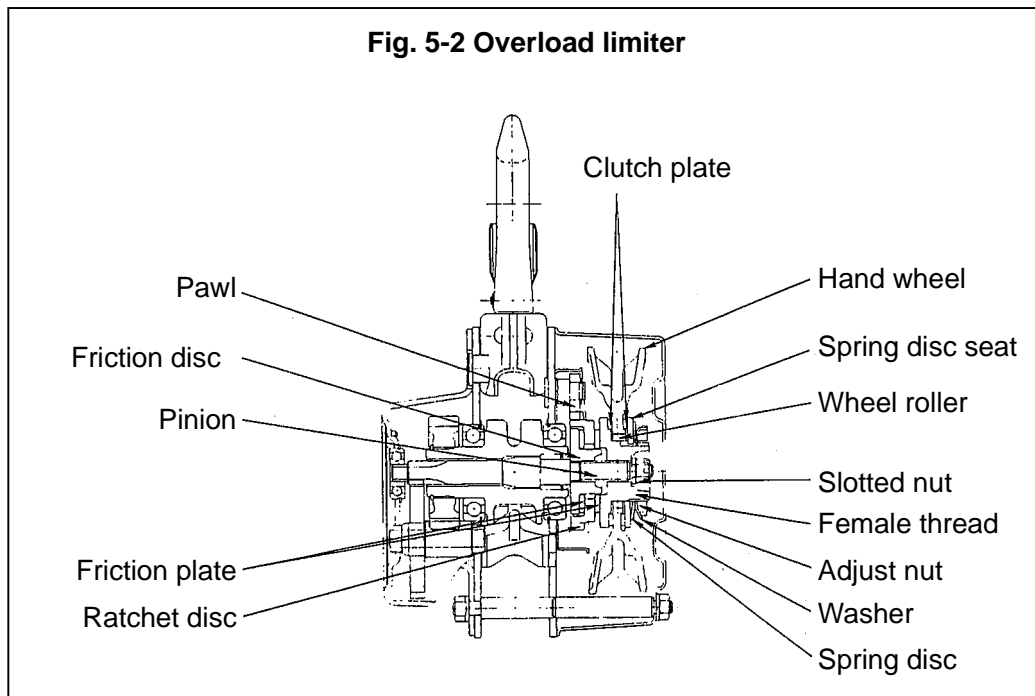

Note:

When the overload limiter operates, the maximum load to the product is approximately 1.8 times of the rated load.

If the overload limiter operates, reduce the load to less than the rated load.

Also check that the structure for mounting the chain hoist (including a trolley) has no damage.

7. INSPECTION

7.1 Outline

There are two types of inspection, the daily inspection performed by the operator before using the hoist, and the more thorough periodic inspection performed by qualified service personnel who have the authority to remove the hoist from service.

7.2 Daily inspection

Before each work shift, check the following points:

Item	Inspection method	Discard limit/criteria	Remedy
1. Name plate	Check visually.	Every description should be clear and visible.	Replace the name plate.
2. Hook latches (Top/bottom)	Check visually.	The top and bottom hook latches shall be in proper condition.	Replace the latch or hook.
3. Hook	Check visually.	The openings of the top and bottom hooks shall not be apparently too wide.	Replace the hook.
	Check visually.	No wear, deformation or damage.	Replace the hook.
	Turn the swivels by hand.	The swivels should rotate freely.	Replace the hook.
4. Load chain	Check visually.	No twisting.	Replace the deformed chain.
	Check visually.	No excessive rust or corrosion.	Replace the load chain.
5. Brake	Facing the hand chain side, operate the hoist with no load.	The pawl should emit a clear clicking sound while lifting.	Repair if impure noise or no sound.
6. Sound	Listen to the noises.	There should be no irregular noises from hand chain, load chain or gears.	Replace the noisy parts.
7. Miscellaneous	Check visually.	No missing nuts and/or split pins.	Replace the parts.

7.3 Periodic inspection

Periodic inspection shall be made at the interval shown below and should follow the given procedures.

NORMAL (Normal use): Annual inspection
 HEAVY (Frequent use): Semiannual inspection
 SEVERE (Excessively frequent use): Quarterly inspection

Figures in parentheses are Fig. No. in "PARTS LIST". (Refer to page 27 to 32.)

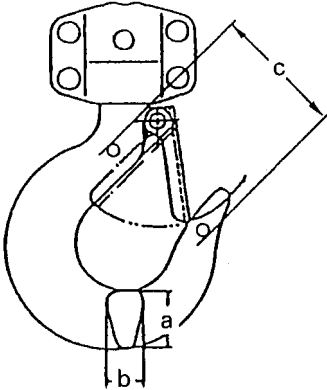
Item	Inspection method	Discard limit/criteria	Remedy																																																																
Indications	Check visually.	WLL indication is clear.	Attach the name plate.																																																																
Hook [1, 6, 55, 78] (Top and bottom)																																																																			
1. Deformation/ twist of hook opening	Measure dimension "c" at time of purchase with slide calipers. Check visually.	No deformation comparing with original shape (at time of purchase). Twist shall not be large enough to detect visually.	Replace the hook. Replace the hook.																																																																
2. Wear	Measure "a" and "b" with slide calipers.	NEVER use the hook if dimension "a" or "b" becomes less than 90% of normal.	Replace the hook.																																																																
																																																																			
<table border="1"> <thead> <tr> <th rowspan="2">WLL (t)</th> <th colspan="2">a (mm)</th> <th colspan="2">b (mm)</th> </tr> <tr> <th>Normal</th> <th>Discard</th> <th>Normal</th> <th>Discard</th> </tr> </thead> <tbody> <tr><td>0.5</td><td>17.0</td><td>15.3</td><td>12.1</td><td>10.9</td></tr> <tr><td>1</td><td>21.8</td><td>19.6</td><td>16.0</td><td>14.4</td></tr> <tr><td>1.5</td><td>26.5</td><td>23.9</td><td>19.5</td><td>17.6</td></tr> <tr><td>2</td><td>30.0</td><td>27.0</td><td>21.8</td><td>19.6</td></tr> <tr><td>2.5</td><td>33.5</td><td>30.2</td><td>24.3</td><td>21.9</td></tr> <tr><td>3</td><td>37.5</td><td>33.8</td><td>27.2</td><td>24.5</td></tr> <tr><td>5</td><td>47.5</td><td>42.8</td><td>34.5</td><td>31.1</td></tr> <tr><td>7.5</td><td>63.0</td><td>56.7</td><td>47.5</td><td>42.8</td></tr> <tr><td>10</td><td>63.0</td><td>56.7</td><td>47.5</td><td>42.8</td></tr> <tr><td>15</td><td>80.0</td><td>72.0</td><td>50.0</td><td>45.0</td></tr> <tr><td>20</td><td>90.0</td><td>81.0</td><td>56.0</td><td>50.4</td></tr> </tbody> </table>				WLL (t)	a (mm)		b (mm)		Normal	Discard	Normal	Discard	0.5	17.0	15.3	12.1	10.9	1	21.8	19.6	16.0	14.4	1.5	26.5	23.9	19.5	17.6	2	30.0	27.0	21.8	19.6	2.5	33.5	30.2	24.3	21.9	3	37.5	33.8	27.2	24.5	5	47.5	42.8	34.5	31.1	7.5	63.0	56.7	47.5	42.8	10	63.0	56.7	47.5	42.8	15	80.0	72.0	50.0	45.0	20	90.0	81.0	56.0	50.4
WLL (t)	a (mm)		b (mm)																																																																
	Normal	Discard	Normal	Discard																																																															
0.5	17.0	15.3	12.1	10.9																																																															
1	21.8	19.6	16.0	14.4																																																															
1.5	26.5	23.9	19.5	17.6																																																															
2	30.0	27.0	21.8	19.6																																																															
2.5	33.5	30.2	24.3	21.9																																																															
3	37.5	33.8	27.2	24.5																																																															
5	47.5	42.8	34.5	31.1																																																															
7.5	63.0	56.7	47.5	42.8																																																															
10	63.0	56.7	47.5	42.8																																																															
15	80.0	72.0	50.0	45.0																																																															
20	90.0	81.0	56.0	50.4																																																															
3. Hook damage	Check visually.	No great damage permitted such as bend, deep scratch and torsion, etc..	Replace the hook.																																																																
4. Hook movement	Swivel hook.	Shall swivel smoothly.	Replace the hook.																																																																

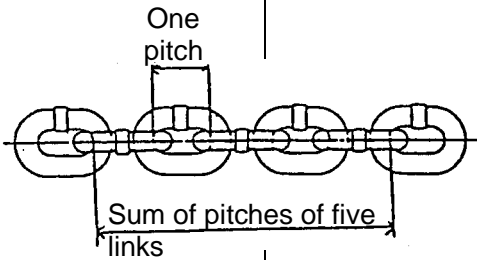
Item	Inspection method	Discard limit/criteria	Remedy																		
5. Top/bottom fixture damage [Fittings of 1, 6, 55, 78]	Check visually.	No slack or missing rivets, nuts or bolts.	Replace the hook.																		
6. Idle sheave rotation [57, 81]	Hold the load chain with both hands and turn the idle sheave by moving the chain up and down.	Stiff rotation.	Replace.																		
7. Hook latch [2, 7, 56, 80]	Check visually.	Proper positioning and smooth working.	Replace the hook latch or hook.																		
Load chain [47, 110]																					
1. Wear	Measure with slide calipers.	Measure the sum of pitches of five chain links and check that the maximum length does not exceed value shown in table below.	Replace the chain.																		
																					
		<table border="1"> <thead> <tr> <th>WLL (t)</th> <th>Sum of pitches of five links (mm)</th> <th>Discard limit (mm)</th> </tr> </thead> <tbody> <tr> <td>0.5</td> <td>75.5</td> <td>77.7</td> </tr> <tr> <td>1</td> <td>95.5</td> <td>98.3</td> </tr> <tr> <td>1.5, 3</td> <td>106.0</td> <td>109.1</td> </tr> <tr> <td>2</td> <td>121.0</td> <td>124.6</td> </tr> <tr> <td>2.5, 5, 7.5, 10, 15, 20</td> <td>136.0</td> <td>140.0</td> </tr> </tbody> </table>	WLL (t)	Sum of pitches of five links (mm)	Discard limit (mm)	0.5	75.5	77.7	1	95.5	98.3	1.5, 3	106.0	109.1	2	121.0	124.6	2.5, 5, 7.5, 10, 15, 20	136.0	140.0	
WLL (t)	Sum of pitches of five links (mm)	Discard limit (mm)																			
0.5	75.5	77.7																			
1	95.5	98.3																			
1.5, 3	106.0	109.1																			
2	121.0	124.6																			
2.5, 5, 7.5, 10, 15, 20	136.0	140.0																			
2. Rust, flaw, deformation	Check visually. Check visually.	No obvious rust (Apply oil as necessary). No twist or harmful flaw.	Remove rust. Replace the load chain.																		
Hook yoke (Top set [1,54]) (Bottom set [6, 77]) Joint of top/bottom fixtures with top pin [4] and chain pin [8, 106]	Measure hole diameter of joint area in two directions at right angle.	Deformation not permitted (if each measured value differs more than 0.5mm).	Replace the part.																		

Item	Inspection method	Discard limit/criteria	Remedy
Function			
1. Lifting and lowering	Lift and lower a light load.	No abnormal difficulty in lifting or lowering.	Overhaul and service.
2. Brake	Lift and lower a light load.	Confirm that none of the problems listed below occur during lifting and lowering: (1) Lifting impossible. (2) Load falls when the operator removes his hands. (3) Load falls during unwinding. (4) Load slips down slowly.	Overhaul and service.
Brake (Inside mechanism)	Overhaul and check.		

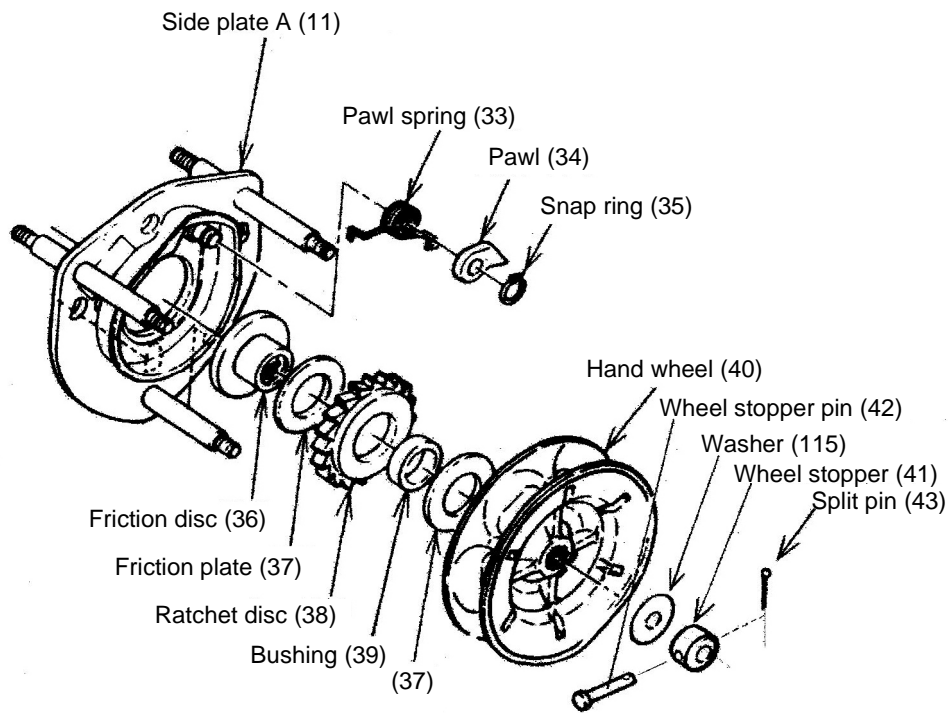

1. Flaw on brake surface [36,37, 38, 39]	Check visually.	Should free of scars or gouged flaws on the braking surface. The braking surface should not be excessively worn with the tool marks erased and surface lustered.	Replace the part.
2. Wear on friction plate [37]	Measure with slide calipers.	Retain uniform thickness and friction plates shall not be worn more than 0.5 mm. For all types: Normal thickness: 3 mm Discard limit: 2.5 mm	Replace the part.

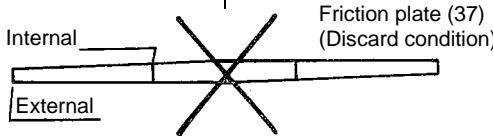
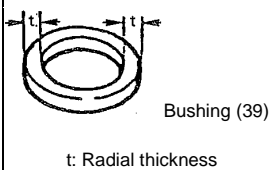
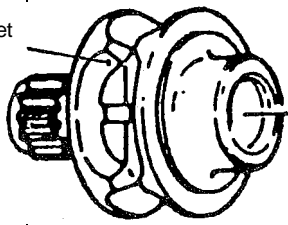
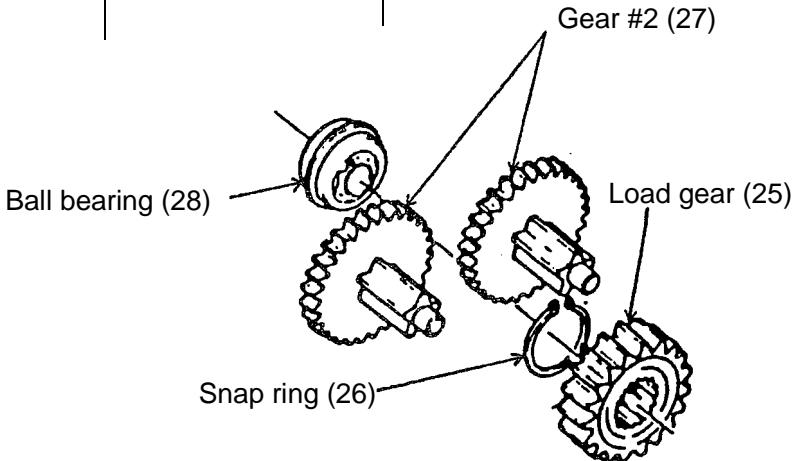
Item	Inspection method	Discard limit / criteria	Remedy									
<p>3. Flatness of friction plate [37]</p>	<p>Check clearance with straight gauge.</p> 	<p>Clearance shall be uniform. Internal part shall not be thicker than external part.</p>	<p>Replace the part.</p>									
<p>4. Wear and oil of bushing [39]</p>	<p>Check radial thickness (t) with slide calipers and oil existence.</p>  <p>t: Radial thickness</p>	<p>Radial thickness (t) shall be uniform. Oil shall be contained. Refer to table below.</p> <table border="1" data-bbox="742 672 1380 840"> <thead> <tr> <th>WLL (t)</th> <th>Normal thickness: t (mm)</th> <th>Discard limit (mm)</th> </tr> </thead> <tbody> <tr> <td>0.5, 1, 1.5, 3</td> <td>3</td> <td>2</td> </tr> <tr> <td>2, 2.5, 5, 7.5, 10, 15, 20</td> <td>4</td> <td>3</td> </tr> </tbody> </table>	WLL (t)	Normal thickness: t (mm)	Discard limit (mm)	0.5, 1, 1.5, 3	3	2	2, 2.5, 5, 7.5, 10, 15, 20	4	3	<p>Replace the part.</p>
WLL (t)	Normal thickness: t (mm)	Discard limit (mm)										
0.5, 1, 1.5, 3	3	2										
2, 2.5, 5, 7.5, 10, 15, 20	4	3										
<p>5. Wear and rust of ratchet disc [38]</p>	<p>Check visually.</p> <p>Check visually.</p>	<p>The tooth wear shall not be more than 1.5 mm.</p> <p>No rust</p>	<p>Replace the part.</p> <p>Replace the part.</p>									
Lifting system												
<p>1. Wear and deformation of load sheave [14]</p>	<p>Check visually.</p> 	<p>No large wear, no deformation or no burr due to load chain contact is permitted on the surface of load chain pocket.</p>	<p>Replace the part.</p>									
<p>2. Wear and flaw of gear [25, 27]</p>	<p>Check visually.</p> 	<p>Teeth shall be free from large wear flaw.</p>	<p>Replace the part.</p>									

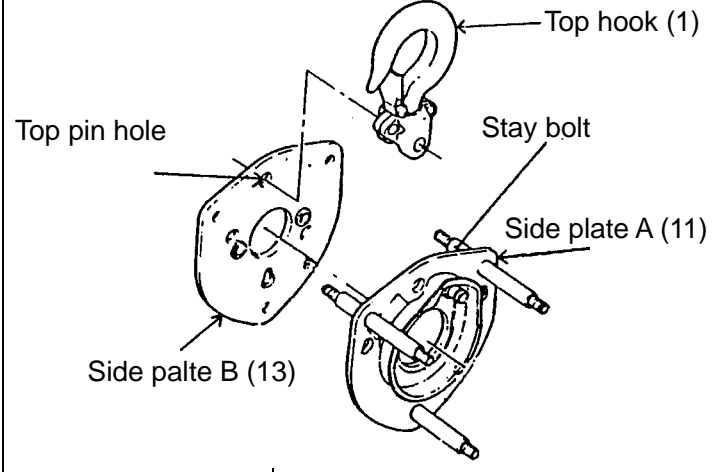
Item	Inspection method	Discard limit/criteria	Remedy
3. Wear and deformation of hand wheel [40]	Check visually. Check visually.	No large wear or no deformation on the surface of hand chain pocket Turn and check if it touches the cover.	Replace the part. Replace the part.
Side plate [11, 13] 1. Deformation of top pin hole 2. Slack stay bolt restraint	Check visually. Check by hand.	Hole shall not be oval. No slack is permitted. 	Replace the part. Replace the side plate.
Miscellaneous 1. Deformation of stripper [21] 2. Flaw on guide roller [20]	Check visually. Check visually. Check visually.	No large crush or damage on stripper tip is permitted. Shall turn lightly. No large deformation.	Replace the part. Replace the part. Replace the part.

8. MAINTENANCE AND STORAGE

⚠ WARNING

- (1) **NEVER** perform maintenance on the hoist while it is supporting a load.
- (2) Before performing maintenance, attach the tag.
[“DANGER”: **NEVER OPERATE EQUIPMENT BEING REPAIRED.**]
- (3) Only allow qualified service personnel to perform maintenance.
- (4) After performing any maintenance on the hoist, **ALWAYS** test to WLL before returning to service.
- (5) When replacing a part, be sure to use the genuine part for “KITO chain hoist model M3CB”.

⚠ CAUTION

ALWAYS indicate “CHECKING” when performing the inspection.

ALWAYS wear protection equipment such as protection goggles and gloves depending on the work contents.

ALWAYS pay attention to work method, work procedure and work posture.

ALWAYS remove the oil or grease attached to the product or spilt on the floor.

ALWAYS keep the work area clean when disassembling the product.

ALWAYS take care hand or clothes not to be caught in a chain, idle sheave or other moving parts.

Care

- Do not drag or throw the chain hoist when carrying.
- Never apply oil to the braking part such as braking surface of friction plate.
- Wipe off dust and moisture, and apply oil to the neck of hook and the load chain.

Storage

- When not in use, ensure that it does not encumber other works.
- Store the hoist in an appropriate dry area indoors, taking care of the weight and size.
- When installing outdoors, cover the hoist to avoid exposure to rain or store in a place with covering against rain.
- Before storing the hoist, pull the hand chain by about 10cm to lower the hook and ensure that the brake is released.

8.1 Lubrication

8.1.1 Applying grease to gears

Unscrew nuts (31), on the opposite side of hand chain wheel, and remove spring washers (32) and gear case (29). Remove old grease and replace with new grease (standard grease⁽¹⁾), at annual inspection.

Temperature range of standard grease is -40°C to +60°C.

If the hoist is used at temperature below -40°C or above +60°C, consult KITO or authorized KITO dealer since some parts shall be changed.

Note: ⁽¹⁾ Recommended brand: SHELL Albania #3 or calcium soap grease equivalent of NLGI (National Lubricating Grease Institute)/#3

8.1.2 Load chain

⚠ WARNING

Failure to maintain clean and well lubricated load chain will void the manufacturer's warranty.

ALWAYS lubricate load chain weekly, or more frequently, depending on severity of service.

ALWAYS lubricate more frequently than normal in a corrosive environment.⁽²⁾

ALWAYS use rust preventive oil equivalent to ISO VG32.

Note: ⁽²⁾ KITO has a corrosion-resistant chain as an option.

For information on KITO's regular and corrosion-resistant chain, please ask KITO or authorized KITO dealer.

8.2 Overhaul, assembly and adjustment

8.2.1 Overhaul

Figures in parentheses are Fig. No. in "PARTS LIST". (Refer to page 27 to 32)

To disassemble or reassemble the hoist, prepare for the following tools.

- External snap ring plier
- Internal snap ring plier
- Wrenches 10mm, 12mm, 13mm, 14mm, 17mm, 19mm
- Pliers
- Plastic hammer

Overhaul procedures	Remarks
<ol style="list-style-type: none">1. Put a hoist with wheel cover side up.2. Unscrew three nuts [45] (with the spring washers [46]) fixing the wheel cover [44] and remove the wheel cover from the side plate A [11].3. Remove the hand chain [48] from the hand wheel [40].4. Pull out the split pin [43] from the wheel stopper pin [42] and remove the wheel stopper pin and the wheel stopper [41] from the pinion [17].5. Remove the hand wheel [40] from the pinion [17] by turning the hand wheel counterclockwise.	<p>If the hand wheel is too tight to turn by hand, put the hand chain on the hand wheel back again and pull it down hard. It will release the brake.</p>

Overhaul procedures	Remarks
<p>6. Remove two friction plates [37], the ratchet disc [38] and the bushing [39] from the friction disc [36].</p> <p>7. Unscrew the friction disk [36] from the pinion [17] by turning counterclockwise holding the end of the pinion with fingers.</p> <p>8. Remove the snap ring [35] from the pawl pin (on the side plate A) and then remove the pawl [34] and pawl spring A and B [33].</p> <p>9. <For 7.5 t and smaller types> Pull the split pin [24] out from the stopper pin [23] and remove the load chain [47] and the stopper pin from the anchorage [22]. <For 10t and larger types> Pull the split pin [52] out from the end pin [51] and remove the load chain [47] and the end pin. Unscrew two socket bolts (with the spring washers) fixing the stoppers [114] and remove stoppers.</p> <p>10. Remove the load chain [47] from the load sheave [14] by pulling the load chain toward the bottom hook.</p> <p>11. Remove the split pin [5] from the top pin [4], then remove the top pin and the top hook [1] from the side plate A [11] and B [13].</p> <p>12. Put the hoist with gear case side (or name plate side) up.</p> <p>13. Unscrew three nuts [31] (with the spring washers [32]) fixing the gear case [29], remove the gear case from the side plate B [13], and take the ball bearings [28] out from the gear case.</p> <p>14. Remove the two gears #2 [27] (0.5t has one) from the side plate B [13].</p> <p>15. Remove the snap ring [26] from the load sheave [14], then the load gear [25] from the load sheave.</p> <p>16. Remove the side plate B [13] from the side plate A [11] and then take the ball bearing [16] out from the side plate B.</p> <p>17. Remove the guide rollers [20], load sheave (attached to the pinion [17]), stripper [21] and anchorage [22] (For 10t and larger types: cross guide [53]) from the side plate A [11], then remove the ball bearing [15] from the side plate A.</p> <p>18. Remove the snap ring [19] inside the load sheave [14].</p> <p>19. Remove the pinion [17] and the roller bearing [18] from the load sheave [14].</p> <p>20. Pull the split pin [10] out from the slotted nut [9] and remove the slotted nut and chain pin from the bottom hook [6].</p>	<p>Hold the load sheave with a hand and remove the bearing by tapping the pinion with a wooden or plastic hammer.</p>

8.2.2 Assembly and adjustment

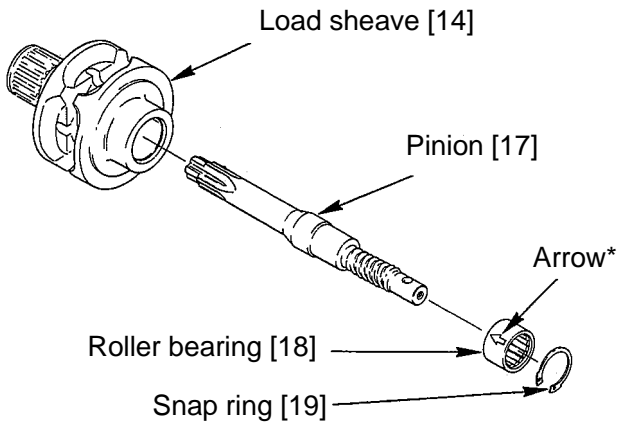
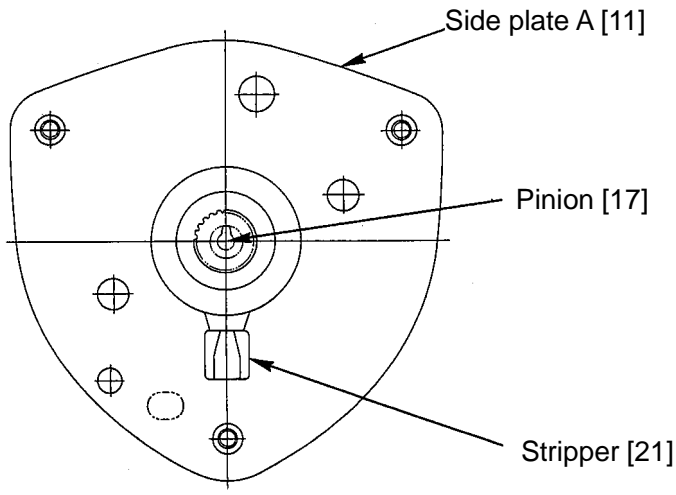
Assembly procedures	Remarks
<p>1. Apply grease to the rollers of the roller bearing [18] and insert the pinion [17] (from the side of the brake screw) into the roller bearing and insert them together into the load sheave [14]. Fix them with a snap ring [19].</p>  <p>2. Put the side plate A [11] with a brake cover side down and insert the ball bearing [15] (with a snap ring side up) into the side plate A. Grease the balls of ball bearing shown in the side plate A.</p> <p>3. Insert the load sheave [14] with a part of involute serration side (pinion gear side) up into the ball bearing [15]. The stripper [21] must be put as well.</p>  <p>4. <For 7.5t and smaller types> Put the guide rollers [20] and the anchorage [22] on the side plate A [11]. <For 10t and larger types> Put the guide rollers [20] and the cross guide [53] on the side plate A [11].</p>	<p>The arrow* direction on the outer side of the roller bearing shall be faced to pinion gear side. When inserting, use proper jig such as pipe on the bearing and tap it with a wooden or plastic hammer. Always make sure that the snap ring is correctly seated.</p> <p>Put the cross guide so that the longer arm fits to the side plate A.</p>

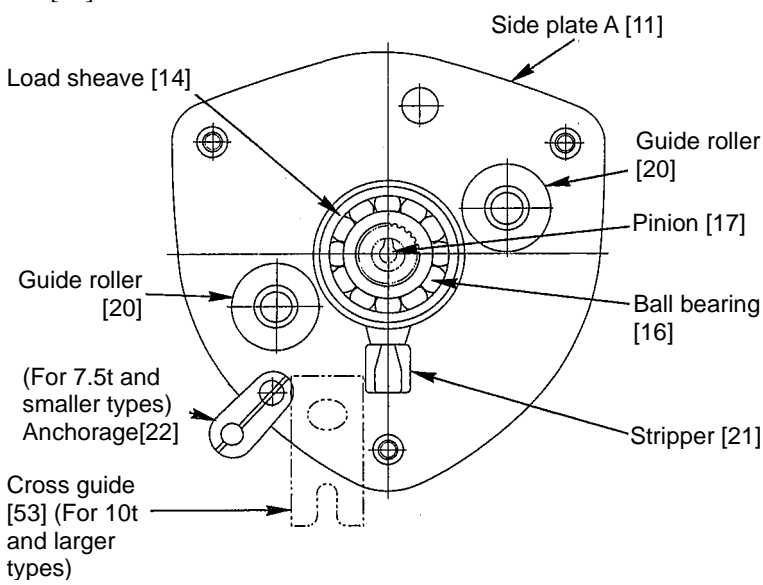
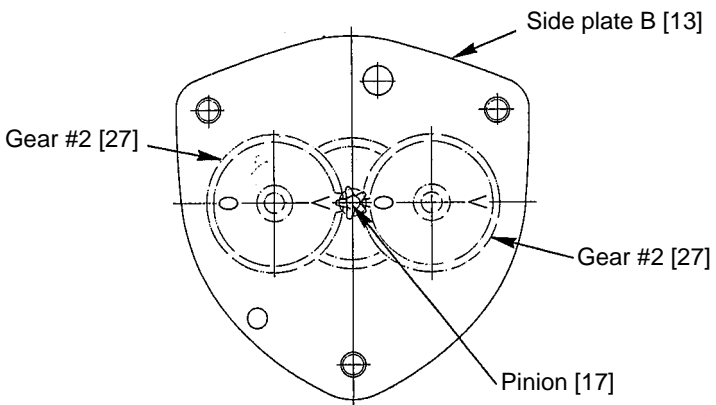
Assembly procedures	Remarks
<p>5. Grease the balls of the ball bearing [16]. Insert it with the snap ring side down to the shaft of the load sheave [14].</p> 	<p>As for the ball bearing of the load sheave, make sure that the snap ring is placed on the side of the load sheave where the load chain reeves.</p>
<p>6. Join the side plate B [13] to the side plate A [11].</p> <p>7. Mesh the load gear [25] with the involute serration of the load sheave [14] and fix it with a snap ring [26].</p> <p>8. Grease the two gear #2 [27], the load gear [25] and the gear of the pinion [17]. Put them in the plain bearing (bearing A) of the side plate B [13]. Letters O and V on the gears must face to each other as shown in the below figure. Do not forget to apply grease to the boss on the both sides of the gear #2.</p>	<p>In case it is difficult to join the two, tap it with a wooden or plastic hammer. Be careful not to let the stripper, guide roller, and anchorage fall down.</p> <p>ALWAYS make sure the snap ring is completely set at the bottom of the groove.</p> <p>It is not necessary to adjust the letters in case of the 0.5t type, for it has only one gear #2.</p>
	

Assembly procedures	Remarks
<p>9. Grease the balls of the ball bearing [28] and insert it with the snap ring down into the end of the pinion [17] shaft.</p> <p>10. Join the gear case [29] to the side plate B [13] and fix them with the three spring washers [32] and nuts [31].</p> <p>11. Place the top hook [1] between the side plate A [11] and B [13]. Then insert top pin [4], and fix it with the split pin [5].</p>	<p>ALWAYS bend the split pin securely after inserting it into the top pin.</p>
<p>12. Place the hand wheel [40] side upward.</p>	

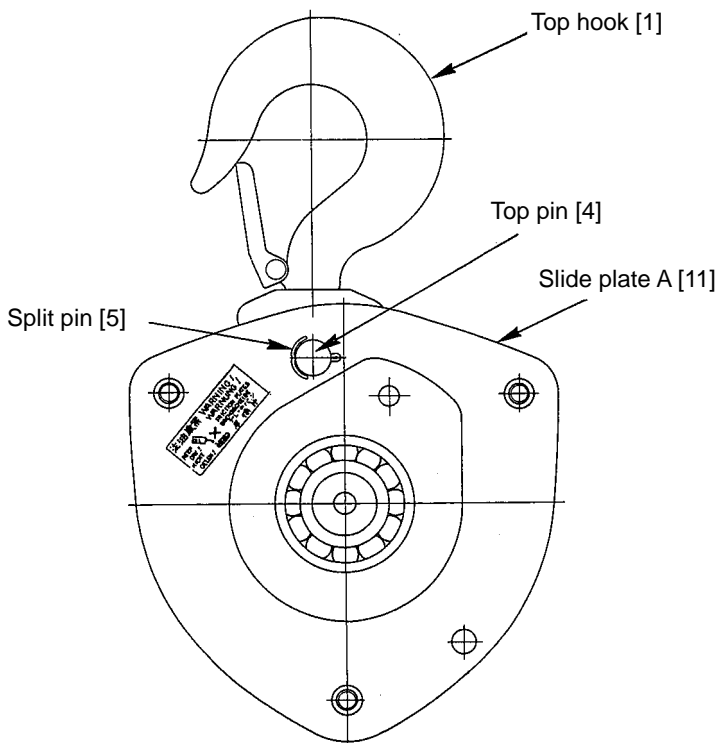

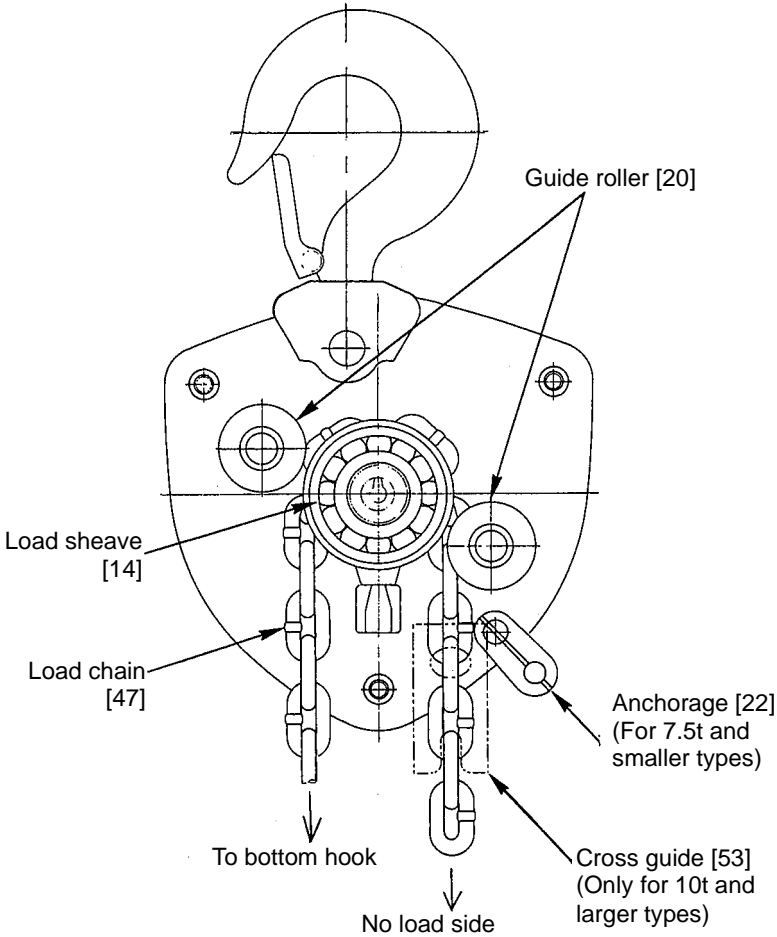
Assembly procedures	Remarks
<p data-bbox="165 271 916 360">13. Reeve the load chain [47] turning the pinion [17] shaft clockwise through the space between the left (bottom hook side) guide roller [20] and the load sheave [14].</p> <p data-bbox="205 495 903 555">For 10t or larger types, pass the no load end of the chain through the cross guide [53].</p> 	<p data-bbox="960 271 1417 389">Put the welded part of the standing chain link outward and reeve it through the load sheave. Pull it out between the right guide roller (no load side) and the load sheave.</p> <p data-bbox="960 495 1390 613">It is recommended for this process to position the unit so that the side plate A [11] faces left and the side plate B [13] faces right.</p>

Assembly procedures

Remarks

14. <For 7.5t and smaller types>

- Pull the end of the load chain [47] out between the right guide roller [20] and the load sheave [14] (no load side) and insert it to the anchorage [22]. Insert the stopper pin [23] and fix it with a split pin [24].

Make sure the load chain is not twisted and the split pin in the stopper pin is bent thoroughly.

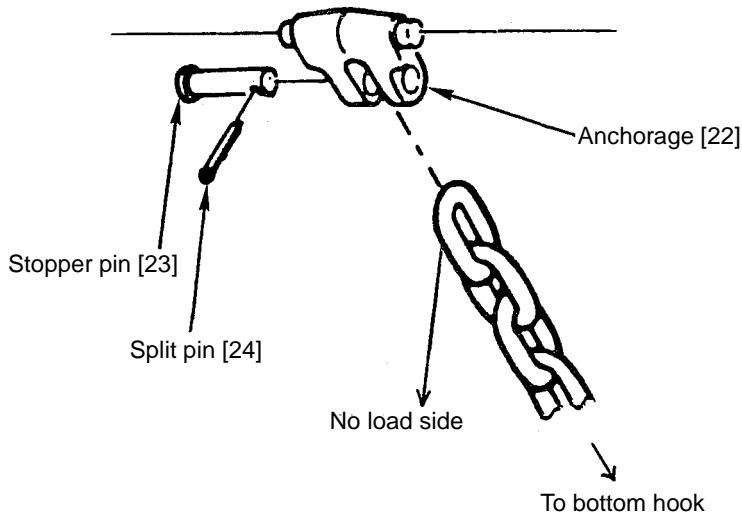

<For 10t and smaller types>

Connect the no load end of the load chain [47] to end pin [51] which is to be inserted from gear case [29] side. Use a split pin [52] to secure the end pin. Fix stoppers [114] to the ninth link from the no load end of the load chain by assembling with socket bolts and spring washers.

Threaded hole side of one stopper shall face to non-threaded hole side of the other stopper. Socket bolt shall be inserted from the non-threaded side.

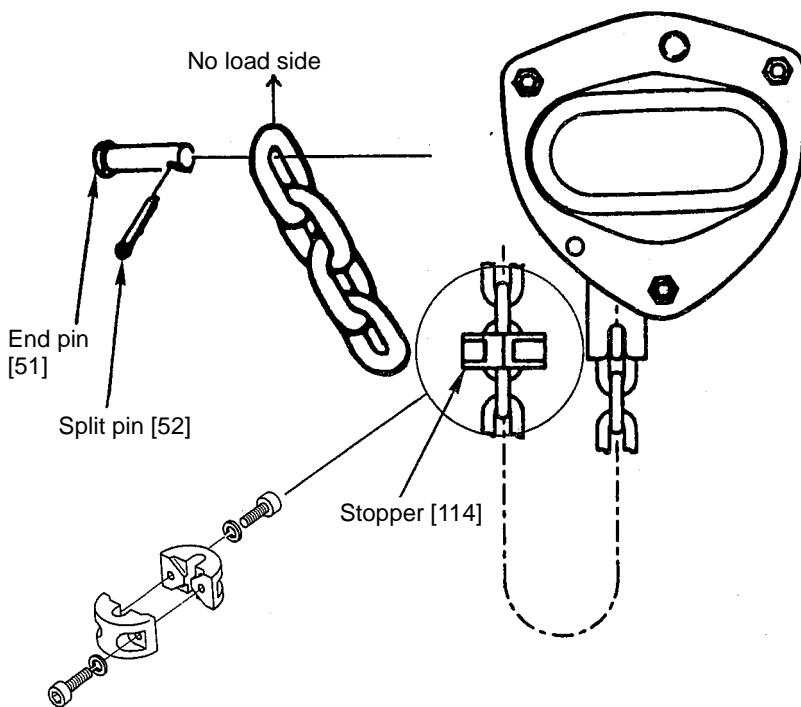

Assembly procedures	Remarks
<p>15. Apply recommended oil* to the pawl pin (in side plate A [11]) and join the pawl spring A, B [33] and the pawl [34] respectively to it. Fix them with a snap ring [35].</p> <p>* JIS K2246 General Class 1, No.1 (NP-9), Lubricating oil type long-term rust preventive oil (Antirust Terami LN-H, ENEOS)</p> <p>16. Put the friction disc [36] to the pinion [17] shaft (while turning the pawl [34] counterclockwise).</p> <p>17. Wipe out any dirt on the friction disc [36], friction plates [37] and both sides of the ratchet disc [38] and check if the oil of the bushing [39] (bushing with containing oil) is applied enough. Then place the friction plate, bushing, ratchet disc and friction plate respectively on the friction disc. (Make sure that the pawl meshes with the ratchet disc properly)</p>	<p>Make sure the pawl spring is touching the pawl and the snap ring is completely set at the bottom of the groove.</p> <p>▲ WARNING</p> <p>NEVER apply oil since the brake is 'dry-type'. Wipe out thoroughly any oil and dirt on the brake. The gear of the ratchet disc should point at the pawl. Otherwise, the hand wheel cannot be assembled later.</p> <p>However, in case the bushing does not have oil inside, soak it in tarbin oil for a day. Install it in without wiping the oil. Make sure that the pawl meshes with the ratchet disc properly.</p>
	<p>18. Wipe out the dirt of the hand wheel [40] and apply machine oil to the threaded part of it. Screw it in the pinion [17] shaft all the way down.</p> <p>19. Place the wheel stopper [41] on the head of the pinion [17], insert the wheel stopper pin [42] and fix it with a split pin [43].</p> <p>ALWAYS bend the split pin securely after inserting into the wheel stopper pin.</p>

Assembly Procedures

Remarks

20. Put the hand chain [48] around the hand wheel [40].

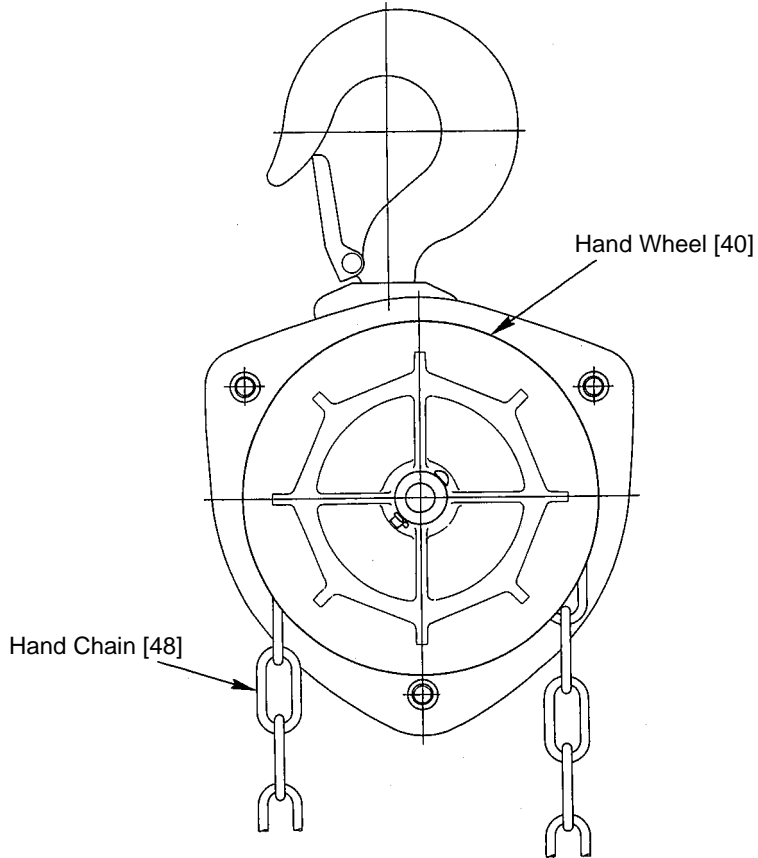

21. Join the wheel cover [44] to the side plate A [11] and fix them with the spring washers [45] and the nuts [46].

22. Insert the other end of the load chain [47] to the bottom hook [6] and fix them with the chain pin [8], slotted nut [9] and split pin [10].

ALWAYS bend the split pin securely.

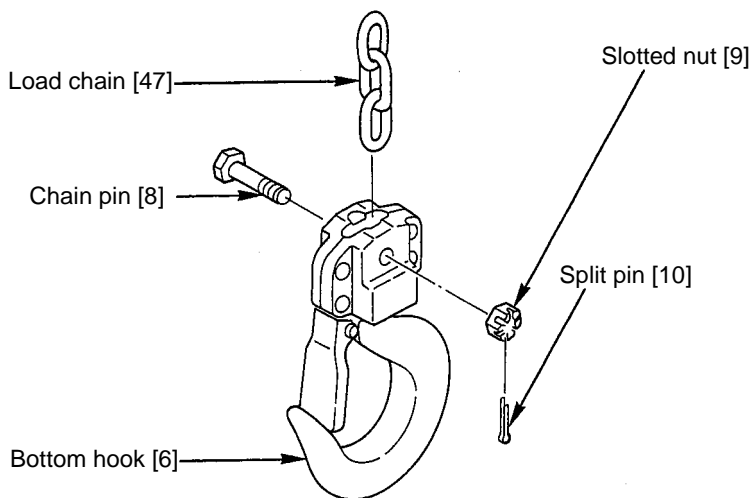

9. TROUBLESHOOTING

Situation	Cause	Explanation	Remedy
The pawl makes the proper clicking sound but fails to lift the load.	Worn friction plates.	When used at high frequency without performing maintenance regularly, the friction plates will wear down. This will create gaps between the friction disc, bushing and hand wheel, and cause the brake to slip.	Disassemble and replace the friction plates and bushing.
The pawl produces absolutely no sound and fails to lift the load.	The pawl has been improperly assembled.	If the pawl is assembled facing the other way, or otherwise assembled incorrectly, it will not cleanly mesh with the ratchet disc.	Disassemble and then reassemble parts correctly.
	The pawl is not moving smoothly.	Unless maintenance is performed regularly, dirt will adhere to the grease on the pawl and pawl shaft. Movement will become sluggish and the pawl will remain stuck in the kicked out position.	Same as above.
The chain is tight when lifting, even without a load. (A squeaking noise can be heard at times.)	Worn gear teeth.	Unless maintenance is performed regularly, greased parts will dry, resulting in wear and damage, and improper meshing of gears.	Disassemble and replace the pinion, gear #2, load gear, gear case, side plate B and ball bearing.
	Worn or damaged bearing.		
Improper lowering or the chain is extremely tight when lowering.	The brake is too tight.	Due to shock during work, or because the load was left suspended for a long period of time, the brake tightened.	Free the brake forcibly by jerking the hand chain.
	The brake is rusted.	Unless maintenance is performed regularly, rusting will occur.	Disassemble and replace parts where necessary.
The instant lowering is started, the load drops.	The braking surface is dirty.	During assembly, the braking surface must be wiped cleaned of dirt.	Disassemble and replace parts when necessary.
	The braking surface is oily.	The braking surface must not be allowed to become soiled with grease or machine oil because it is a dry-type brake.	Disassemble, clean the parts and then reassemble parts. Do not oil or grease the braking surface or friction plates.
Load slipping.	The braking surface is oily.	Same as above.	Same as above.
	The braking surface is dirty.	During assembly, the braking surface must be wiped cleaned of dirt.	Disassemble and then reassemble parts correctly.

10. WARRANTY

KITO Corporation (“KITO”) extends the following warranty to the original purchaser (“Purchaser”) of new products manufactured by “KITO” (KITO’s Products).

- (1) KITO warrants that KITO’s Products, when shipped, shall be free from defects in workmanship and/or materials under normal use and service and “KITO” shall, at the election of “KITO”, repair or replace free of charge any parts or items which are proven to have said defects, provided that all claims for defects under this warranty shall be made in writing immediately upon discovery and, in any event, within one (1) year from the date of purchase of KITO’s Products by “Purchaser” and provided, further, that defective parts or items shall be kept for examination by “KITO” or its authorized agents or returned to KITO’S factory or authorized service center upon request by “KITO”.
- (2) KITO does not warrant components of products provided by other manufacturers. However to the extent possible, “KITO” will assign to “Purchaser” applicable warranties of such other manufacturers.
- (3) Except for the repair or replacement mentioned in (1) above which is “KITO”’s sole liability and purchaser’s exclusive remedy under this warranty, “KITO” shall not be responsible for any other claims arising out of the purchase and use of KITO’s Products, regardless of whether “Purchaser”’s claims are based on breach of contract, tort or other theories, including claims for any damages whether direct, indirect, incidental or consequential.
- (4) This warranty is conditional upon the installation, maintenance and use of KITO’s Products pursuant to the product manuals prepared in accordance with content instructions by “KITO”. This warranty shall not apply to KITO’s Products which have been subject to negligence, misuse, abuse, misapplication or any improper use or combination or improper fittings, alignment or maintenance.
- (5) “KITO” shall not be responsible for any loss or damage caused by transportation, prolonged or improper storage or normal wear and tear of KITO’s Products or for loss of operating time.
- (6) This warranty shall not apply to KITO’s products which have been fitted with or repaired with parts, components or items not supplied or approved by “KITO” or which have been modified or altered.

THIS WARRANTY IS IN LIEU OF ALL OTHER WARRANTIES, EXPRESS OR IMPLIED, INCLUDING BUT NOT LIMITED TO ANY WARRANTY OF MERCHANTABILITY OR OF FITNESS FOR A PARTICULAR PURPOSE.

11. PARTS LIST

When ordering replacement parts, please specify WLL, Fig. No., part No., part name and quantity.

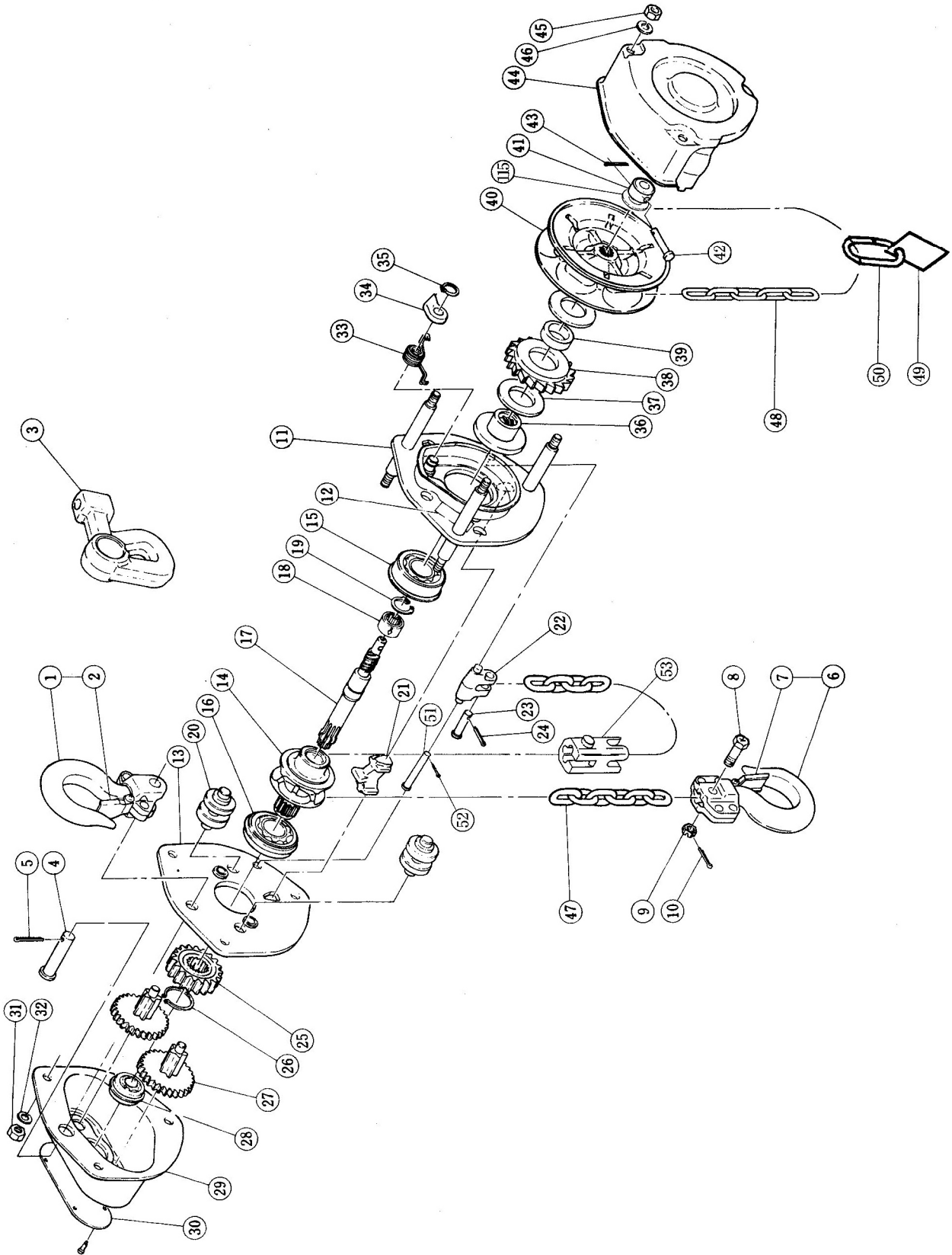

Additional parts for 3t and larger types

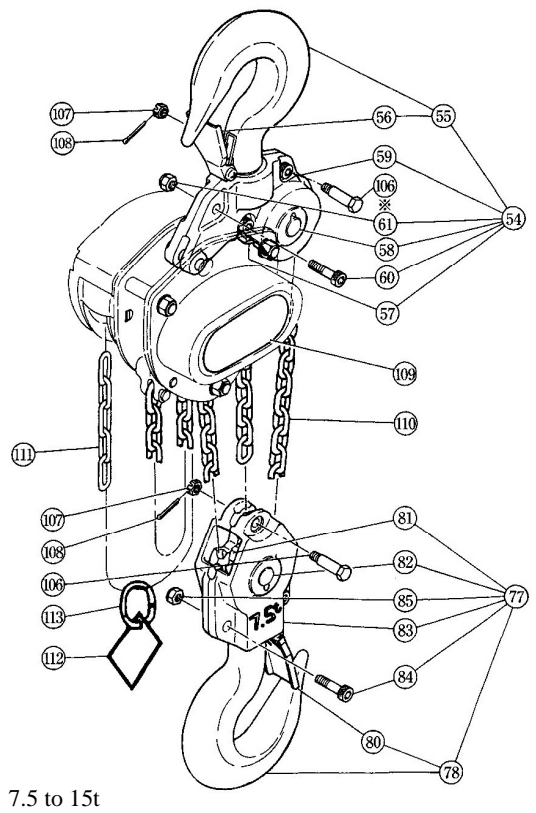
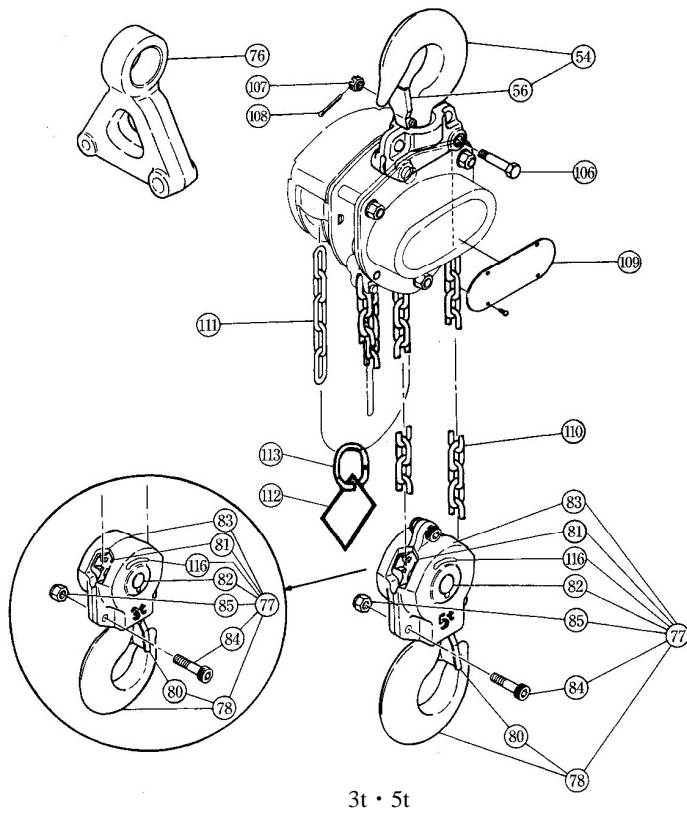

* The Chain pin of 10t model is located on top yoke to connect the Load chain.

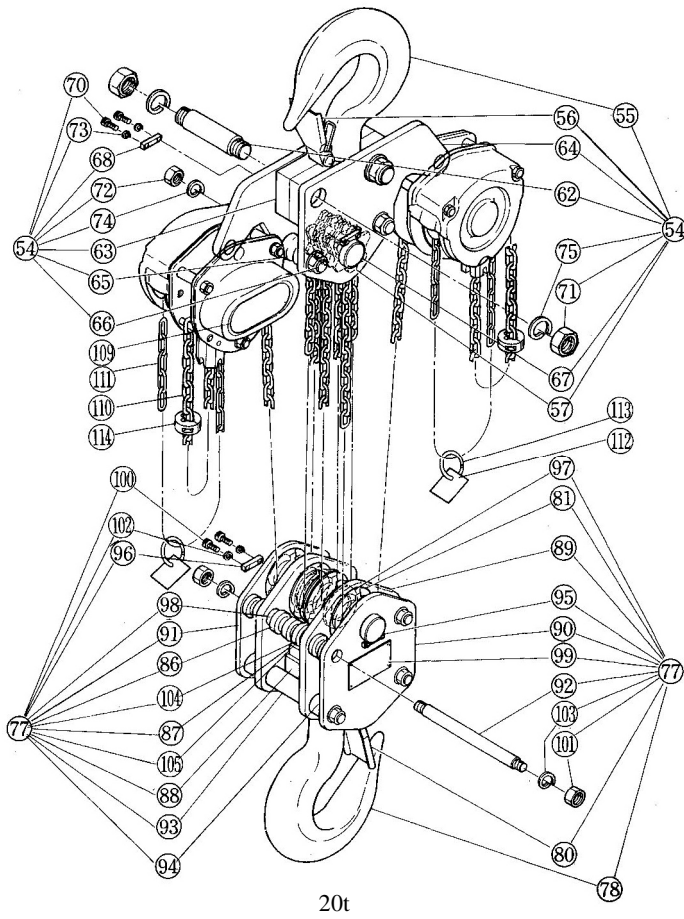

Fig. No.	Part No.	Part name	No. per hoist	WLL (t)					
				0.5	1	1.5	3	2	
1	1001	Top hook set	1	C1FA005-1001	C1FA010-1001	C2FA015-1001	—————	C3BA0200-1001	
2	1071	Hook latch assembly	1	C3BA005-1071	C1FA005-1071	C1FA010-1071	—————	C1FA015-1071	
3	*	Suspender for TSP005	1	T5PC005-9004	—————				
	*	Suspender for TSG010	1	T5GC010-9004					
	*	Suspender	1	—————	T5GC020-9004	—————	T5GC020-9004		
4	163	Top pin	1	C3BA005-9163	C3BA010-9163	C3BA015-9163		C3BA020-9163	
5	198	Split pin	1	J1PW01-030018			J1PW01-030025		
6	1021	Bottom hook set	1	C3BA005-1021	C3BA010-1021	C3BA015-1021	—————	C3BA020-1021	
7	1071	Hook latch assembly	1	C3BA005-1071	C1FA005-1071	C1FA010-1071	—————	C1FA015-1071	
8	41	Chain pin	1	C3BA005-9041	C3BA010-9041	C3BA015-9041	—————	C3BA020-9041	
9	49	Slotted nut	1	C3BA005-9049	C3BA010-9049	C3BA010-9049	—————	C3BA020-9049	
10	96	Split pin	1	J1PW01-016010	J1PW01-020012	J1PW01-020012	—————	J1PW01-020014	
11	5101 (1)	Side plate A assembly	1	C3BA005-5101	C3BA010-5101	C3BA015-5101		C3BA020-5101	
12	806	Name plate F	1	C3BA005-9806					
13	5102 (1)	Side plate B assembly	1	C3BA005-5102	C3BA005-5102	C3BA015-5102		C3BA025-5102	
14	116	Load sheave	1	C3BA005-9116	C3BA010-9116	C3BA015-9116		C3BA020-9116	
15	140	Ball bearing	1	J1GR002-06006					J1GR002-06007
16	145	Ball bearing	1	J1GR002-06005			J1GR002-06006		
17	111 (1)	Pinion	1	C3BA005-9111	C3BA010-9111	C3BA015-9111		C3BA020-9111	
18	130	Roller bearing	1	C3BA005-9130					C3BA020-9130
19	118	Snap ring	1	C3BA005-9118					C3BA020-9118
20	161	Guide roller	2	C3BA005-9161	C3BA010-9161		C3BA015-9161	C3BA020-9161	
21	162	Stripper	1	C3BA005-9162	C3BA010-9162	C3BA015-9162		C3BA020-9162	
22	176	Anchorage	1	C3BA005-9176	C3BA010-9176	C3BA015-9176		C3BA020-9176	
23	177	Stopper pin	1	C3BA005-9177	C3BA010-9177	C3BA015-9177		C3BA020-9177	
24	196	Splint pin	1	J1PW01-020012	J1PW01-025015				
25	114	Load gear	1	C3BA005-9114	C3BA010-9114	C3BA015-9114		C3BA020-9114	
26	117	Snap ring	1	J1SS000-00022			J1SS000-00028		
27	5112 (1)	Gear #2 assembly	(3)	C3BA005-5122	C3BA010-5122	C3BA015-5122		C3BA020-5122	
				1	2	2		2	
28	135	Ball bearing	1	J1GR002-6200					J1GR002-06201
29	6103	Gear case assembly	1	C3BA005-6103	C3BA010-6103	C3BA015-6103		C3BA020-6103	
30	800 (1)	Name plate B with rivets	1	C3BG005-9800	C3BG010-9800	C3BG015-9800	—————	C3BG020-9800	
31	181	Nut	3	J1NA001-20080					J1NA001-20100
32	186	Spring washer	3	J1WS011-20080					J1WS011-20100
33	5179	Pawl spring set (A & B) (2)	1	C3BA005-5179					
34	155	Pawl	1	C3BA005-9155					
35	157	Snap ring	1	J1SS000-00010					
36	153 (1)	Friction disc	1	C3BA005-9153					C3BA020-9153
37	151 (1)	Friction plate	2	C3BA005-9151					C3BA020-9151
38	152 (1)	Ratchet disc	1	C3BA005-9152					C3BA020-9152
39	154 (1)	Bushing	1	C3BA005-9154					C3BA020-9154
40	115 (1)	Hand wheel	1	C3BA005-9115		C3BA015-9115		C3BA020-9115	
41	159	Wheel stopper	1	C1FA005-9159					C1FA015-9159
42	167	Wheel stopper pin	1	C3BA005-9167					
43	199	Split pin	1	J1PW01-020008					
44	5171	Wheel cover assembly	1	C3BA005-5171		C3BA015-5171		C3BA020-5171	
45	182	Nut	3	J1NA001-20080					
46	187	Spring washer	3	J1WS011-20080					
47	841	Load chain	1	K7UN050-00000	K7UN063-00000	K7UN071-00000		K7UN080-00000	
48	842	Hand chain	1	K7NZ050J00000					
49	931	Warning tag	1	ER1BS9686					
50	45	Chain stopper link	1	L5BA032-9045					
51	164	End pin	1	—————					
52	197	Split pin	1	—————					
53	176	Cross guide	1	—————					
115	158	Washer	1	C3BG005-9158					

Notes: * See trolley part lists.

(1) When ordering replacement part, use the symbol M3B in place of M3 for 2.5t, 5t and larger types, because there are no interchangeability.

(2) Pawl spring A and B must be used as a set.

(3) Each number in "WLL" columns is No. per hoist.

Remark: Every part quantity becomes twice of the number in the column "parts per hoist" for 20t hoist.

Fig. No.	Part No.	Part name	No. per hoist	WLL (t)						
				2.5	5	7.5	10	15	20	
1	1001	Top hook set	1	C3BA025-1001						
2	1071	Hook latch assembly	1	C1FA020-1071						
3	*	Suspender for TSP005	1							
	*	Suspender for TSG010	1							
	*	Suspender	1	T5GC025-9004						
4	163	Top pin	1	C3BA025-9163						
5	198	Split pin	1	J1PW01-030025						
6	1021	Bottom hook set	1	C3BA025-1021						
7	1071	Hook latch assembly	1	C1FA020-1071						
8	41	Chain pin	1	C3BA025-9041						
9	49	Slotted nut	1	C3BA020-9049						
10	96	Split pin	1	J1PW01-020014						
11	5101 (1)	Side plate A assembly	1	C3BA025-5101						
12	806	Name plate F	1	C3BA005-9806						
13	5102 (1)	Side plate B assembly	1	C3BA025-5102						
14	116	Load sheave	1	C3BA025-9116						
15	140	Ball bearing	1	J1GR002-06007						
16	145	Ball bearing	1	J1GR002-06007						
17	111 (1)	Pinion	1	C3BA025-9111						
18	130	Roller bearing	1	C3BA020-9130						
19	118	Snap ring	1	C3BA020-9118						
20	161	Guide roller	2	C3BA025-9161						
21	162	Stripper	1	C3BA025-9162						
22	176	Anchorage	1	C3BA025-9176						
23	177	Stopper pin	1	C3BA025-9177						
24	196	Split pin	1	J1PW01-025018						
25	114	Load gear	1	C3BA025-9114						
26	117	Snap ring	1	J1SS000-00032						
27	5112 (1)	Gear #2 assembly	(3)	C3BA025-5122						
				2						
28	135	Ball bearing	1	J1GR002-06201						
29	6103	Gear case assembly	1	C3BA025-6103						
30	800 (1)	Name plate B with rivets	1	C3BG025-9800						
31	181	Nut	3	J1NA001-20120						
32	186	Spring washer	3	J1WS011-20120						
33	179	Pawl spring (A & B) (2)	2	C3BA005-5179						
34	155	Pawl	2	C3BA005-9155						
35	157	Snap ring	2	J1SS000-00010						
36	153 (1)	Friction disc	1	C3BA025-9153						
37	151 (1)	Friction plate	2	C3BA025-9151						
38	152 (1)	Ratchet disc	1	C3BA025-9152						
39	154 (1)	Bushing	1	C3BA020-9154						
40	115 (1)	Hand wheel	1	C3BA025-9115						
41	159	Wheel stopper	1	C1FA015-9159						
42	167	Wheel stopper pin	1	C3BA005-9167						
43	199	Split pin	1	J1PW01-020008						
44	5171	Wheel cover assembly	1	C3BA025-5171						
45	182	Nut	3	J1NA001-20080						
46	187	Spring washer	3	J1WS011-20080						
47	841	Load chain	1	K7UN090-00000						
48	842	Hand chain	1	K7NZ050J00000						
49	931	Warning tag	1	ER1BS9686						
50	45	Chain stopper link	1	L5BA032-9045						
51	164	End pin	1	C3BA100-9164						
52	197	Split pin	1	J1PW01-025018						
53	176	Cross guide	1	C3BA100-9176						
115	158	Washer	1	C3BG005-9158						

Notes: * See trolley part lists.

(1) When ordering replacement part, use the symbol M3B in place of M3 for 2.5t, 5t and larger types, because there are no interchangeability.

(2) Pawl spring A and B must be used as a set.

(3) Each number in "WLL" columns is No. per hoist.

Remark: Every part quantity becomes twice of the number in the column "parts per hoist" for 20t hoist.

Fig. No.	Part No.	Part name	No. per hoist	WLL (t)						
				3(D)	5	7.5	10	15	20	
54	1001	Top hook set	1	C3BA030-1001	C3BA050-1001	C3BA075-1001	C3BA100-1001	C3BA150-1001	C3BA200-1001	
55	1	Top hook	1					C3BA150-9001	C3BA200-9001	
	2001	Top hook assembly	1					C3BA100-2001		
56	1071	Hook latch assembly	1	C1FA020-1071	C1FA030-1071	P1VS200-10712		C2BA150-10711	C3BA200-1071	
								C3BA050-1051		
57	1051	Idle sheave assembly	(3)			1	1	2	3	
58	5053	Shaft assembly	1					C3BA050-5053		
59A	11	Top yoke A	1					C3BA075-9011	C3BA100-9011	
	16	Top yoke A	1					C3BA150-9016		
59B	12	Top yoke B	1					C3BA075-9012	C3BA100-9012	
	17	Top yoke B	1					C3BA150-9017		
60	81	Socket bolt	(3)					J1BE1-1204040		
						5	1			
61	82	Lever nut	(3)					C2BA400-9074		
						5	1			
-	86	Socket bolt	2					J1BE1-1606060		
-	87	U nut	2					C3BA100-9087		
62	10	Top suspension shaft	2					C3BA150-9010	C3BA200-9010	
63	11	Top yoke	2					C3BA200-9011		
64	12	Top plate A assembly	(3)					C3BA150-5012	C3BA200-5012	
								1	1	
-	14	Top plate B	1					C3BA150-9014		
65	18	Guide	(3)					C3BA150-9018		
								4	6	
66	19	Stay bolt	2					C3BA150-9019	C3BA200-9019	
-	43	Top plate	1					C3BA150-9043		
67	53	Top shaft	1					C3BA150-9053	C3BA200-9053	
68	56	Key plate	2					C2BA050-9056		
-	66	Collar	2					C3BA150-9066		
70	83	Socket bolt	4					J1BE1-0801414		
71	84	Nut	4					J1NA001-10300		
72	85	Nut	4					J1NA001-10200		
73	87	Spring washer	4					J1WS011-20080		
74	88	Spring washer	4					J1WS011-20200		
75	89	Spring washer	4					J1WS011-20300		
76	*	Suspender for TSP & TSG	1	T5GC030-9004	T5GC050-9004					
77	1021	Bottom hook set	1	C3BA030-1021	C3BA050-1021	C3BA075-1021	C3BA100-1021	C3BA150-1021	C3BA200-1021	
78	2021	Bottom hook	1					C3BA150-2021	C3BA200-2021	
				C3BA030-2021	C3BA050-21021	C3BA075-2021	C3BA100-2021			
80	1071	Hook latch assembly	1	C1FA020-1071	C1FA030-1071	P1VS200-10712		C2BA150-9071	C3BA200-9071	
				C1FA050-1051	C3BA050-1051		C3BA150-1051	C3BA150-1051		
81	1051	Idle sheave assembly	(3)	1	1	1	1	3	3	
	1052	Idle sheave assembly	2					C3BA100-1052		
82	5053	Shaft assembly	1	C3BA030-5053	C3BA050-5053	C3BA050-5053				
	5054	Bottom shaft assembly	1					C3BA100-5054		
83	2031	Bottom yoke	2	C3BA030-2031	C3BA050-2031	C3BA075-9031	C3BA100-9031			
				J1BE1-1003232		J1BE-1204040				
84	81	Socket bolt	☆(3)	2	3	5				
	88	Socket bolt	2					J1BE1-1605050		
85	82	Lever nut	(3)	C2BA200-9074		C2BA400-9074				
	87	U nut	1	2	3	5				
								C3BA100-90871		
86	18	Guide	(3)					C3BA150-9018		
								4	6	
87	26	Hook Support	2					C3BA150-9026	C3BA200-9026	
88	30	Bottom yoke	1					C3BA150-9030	C3BA200-9030	
89	34	Bottom plate A	(3)					C3BA150-9034	C3BA200-9034	
								1	2	
90	35	Bottom plate B	1					C3BA150-9035	C3BA200-9035	
91	36	Bottom plate C	1					C3BA200-9036		
92	38	Stay-bolt	4					C3BA150-9038	C3BA200-9038	
93	39	Collar A	2					C3BA200-9039		
94	40	Collar B	4					C3BA200-9040		
95	54	Bottom shaft	1					C3BA150-9054	C3BA200-9054	
96	56	Key plate	2					C2BA050-9056	C2BA050-9056	
97	58	Washer A	2					C3BA200-9058		
98	66	Collar	4					C3BA200-9066		
99	69	Name plate A with rivets	1					C3BA150-9069	C3BA200-9069	
100	83	Socketed bolt	4					J1BE1-0801414		
101	85	Nut	8					J1NA001-10200		
102	87	Spring washer	4					J1WS011-20080		
103	88	Spring washer	8					J1WS011-20200		
104	91	Tongued washer	4					C3BA150-90911		
105	92	Bolt	4					J1BA1-1003030		
106	41	Chain pin	1	C3BA030-90411	C3BA050-90411					
107	49	Slotted nut	1	C2BA015-90491	C3BA020-90492					
108	85	Split pin	1	J1PW01-020014						
	97	Split pin	1					J1PW01-020014		
109	800 (1)	Name plate B with rivets	(3)	C3BG030-9800	C3BG050-9800	C3BG075-9800	C3BG100-9800	C3BG150-9800	C3BG200-9800	
				1	1	1	1	1	2	
110	841	Load chain	1	K7UN071-00000	K7UN090-J00000					
111	842	Hand chain	(3)	K7NZ050J00000				1	2	
				1	1	1		1	2	
112	931	Warning tag	(3)	ER1BS9686						
				1				2		
113	45	Chain stopper link	(3)	L5BA032-9045						
				1				2		
114	45	Stopper assembly	(3)					ER1ES10411		
								1	2	
115	158	Washer	1					C3BG005-9158		
116	805	Name plate C	1	C3BA030-9805						

Note : * See trolley part lists.

(1) When ordering replacement part, use the symbol M3B in place of M3 for 2.5t, 5t and larger types, because there are no interchangeability.

(3) Each number in "Capacity Code" columns is Parts per hoist.

ASSEMBLY FOR OVERLOAD LIMITER

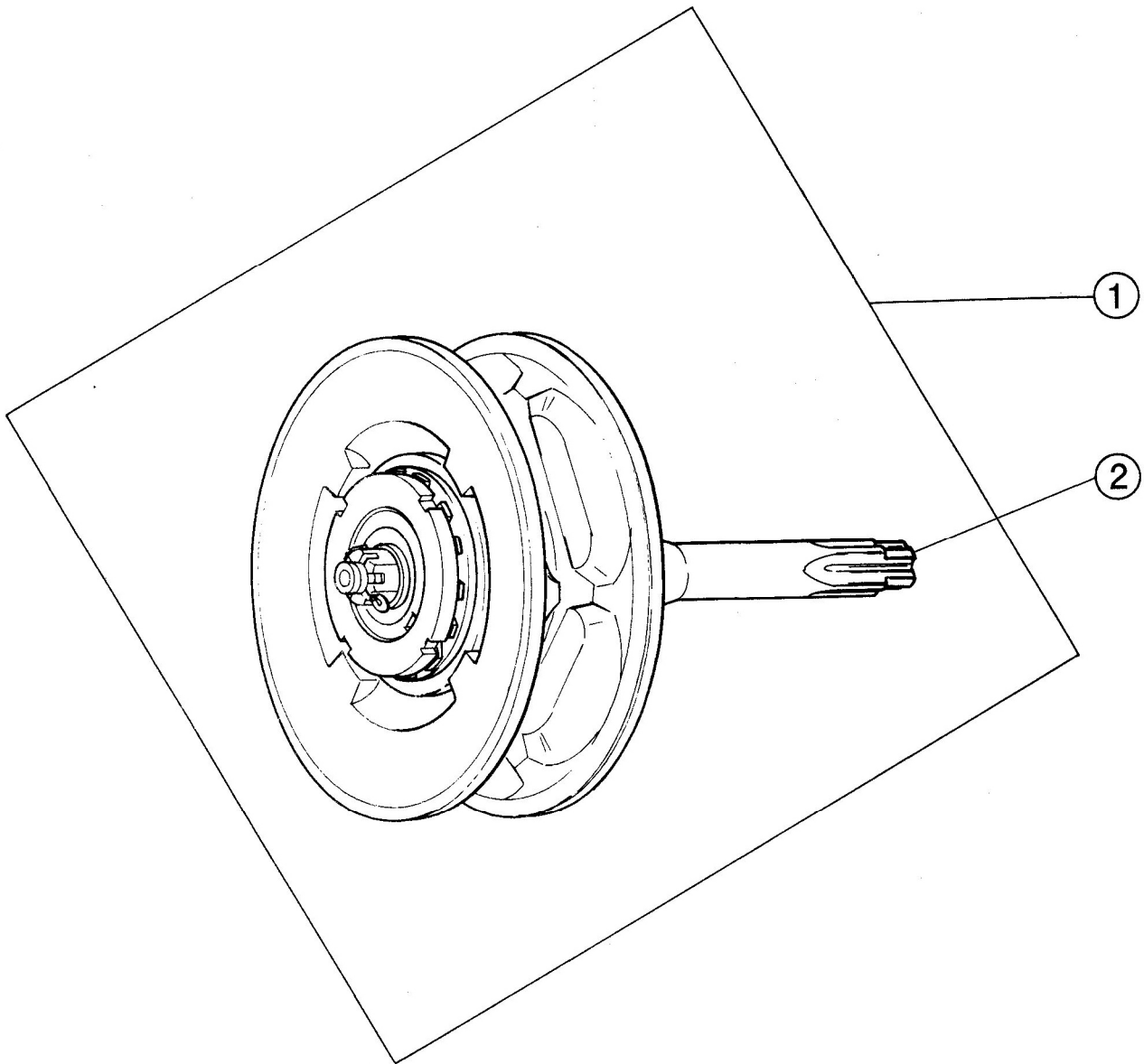

ASSEMBLY FOR OVERLORD LIMITER

Fig. No.	Part No.	Part name	No. per hoist	WLL (t)						
				0.5	1	1.5	3	2	2.5	5
									7.5	10
1	1111	OLL Kit	1	C3YA005-1111	C3YA010-1111	C3YA015-1111	C3YA020-1111	C3YA025-1111		
2	111	Pinion	1	C3YA005-9111	C3YA010-9111	C3YA015-9111	C3YA020-9111	C3YA025-9111		

Note: When ordering replacement, part, use the symbol M3B in place of M3 for 2.5t, 5t and larger types, because there are no interchangeability.

Remark: Every part quantity becomes twice of the number in the column "parts per hoist" for 20t hoist.

KITO

URL. <http://www.kito.com>

KITO Europe GmbH

Heerdter Lohweg 93, D-40549 Düsseldorf, Germany

TEL: +49-(0)211-528009-0

FAX: +49-(0)211-528009-59

E-mail: info@kito.net

URL: <http://www.kito.net>

KITO corporation

Tokyo Head office:

SHINJUKU NS Building 9F, 2-4-1, Nishi-Shinjuku, Shinjuku-ku, Tokyo 163-0809, Japan

URL: <http://www.kito.com>

Head office & Factory:

2000 Tsuijjarai Showa-Cho, Nakakoma-Gun, Yamanashi 409-3853, Japan

URL: <http://www.kito.com>