

LI-120

Automatic Lifting Magnet



Ixtur LI-120 is a battery-powered, electro-permanent magnet, which has a fully automatic operation. LI-120 has a long battery life and it will not change its magnetic state even if the battery dies.

LI-120's automatic control and compact size makes working efficient. LI-120 provides a high level of versatility and efficiency due to its wireless, battery-powered operation that lasts 1500 lifts with one charge.

Due to the magnet's automatic operation, there is no need for the crane operator to be next to the work piece that is being lifted. A remote is not needed, so using LI-120 leaves hands free for other tasks.

TECHNICAL SPECIFICATIONS

Model	Lifting capacity, WLL [kg]	Gripping capacity [kg]	Residual capacity, max [kg]	Dimensions L x W x H [mm]	Weight [kg]	Operating temperature [°C]	Battery life [lifts]	Battery life, stand-by [h]	Charging time [h]	Protection
LI-120	120*	360	20**	125 125 200	6.7	0 ... 50	1500	70	2	IP54

* Safety factor of 3

** The residual gripping capacity varies based on the material and structure of the lifted part. In extreme cases, parts of up to 20 kg may be attached. However, when LI-120 releases the part, an automatic counter-magnetization feature decreases the strength of magnetic attraction temporarily, easing the release of lightweight parts.

LI-120's strong magnetic holding force is created with a permanent magnet. The switching between the magnet's states ("hold/release") is controlled internally with a short electric pulse. Maintaining either of the two states doesn't consume energy, which makes LI-120 energy-efficient and gives it a long battery life.

LI-120 maintains its current magnetic state even if it runs out of battery: the load being lifted will stay attached to the magnet.

LI-120 is designed and manufactured in Finland. Learn more from our website at www.ixtur.com.

Lifting capacity vs. material thickness

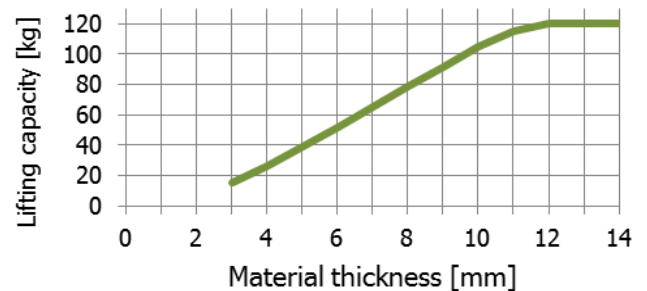

Lifting capacity vs. airgap

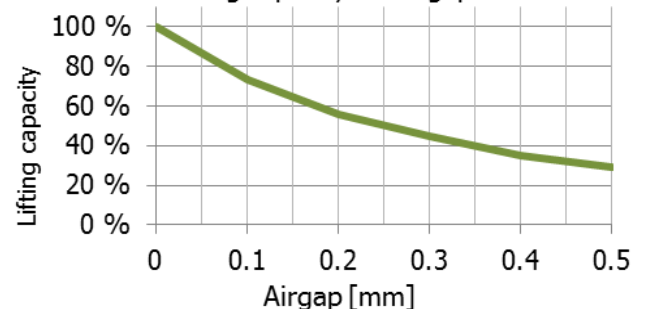

Company • Ixtur Ltd. is a Finnish magnet technology company established in 2010.



PAVLÍNEK
VÁZACÍ PROSTŘEDKY

EMAIL: OBCHOD@PAVLINEK.CZ
TEL: +420 595 693 911
ŠALOUNOVA 746/31, OSTRAVA VÍTKOVICE
IČ: 25358511 DIČ: CZ25358511



LI-120

Automatic Lifting Magnet

LI-120 Technical drawings (all dimensions are in millimetres)

Lifting shaft
(integrated load sensing
= automatic attach/release)

Magnet attach/release
button (when manual
control is preferred)

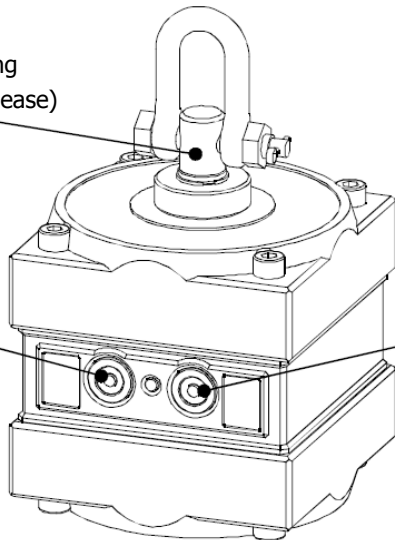

Power ON/OFF
button

Charging terminal

Lifting shackle

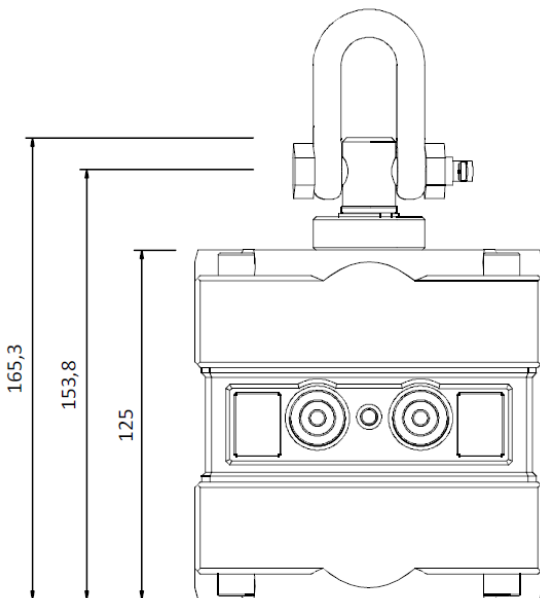
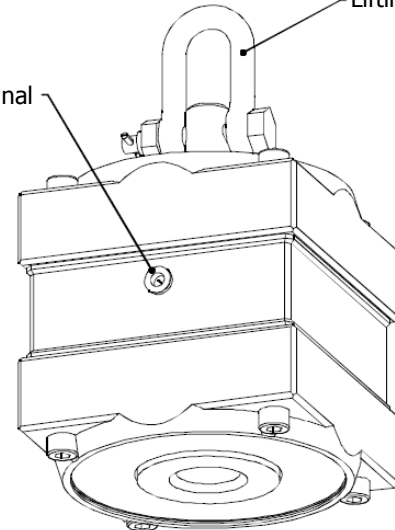

Gripping surface - Magnetic poles

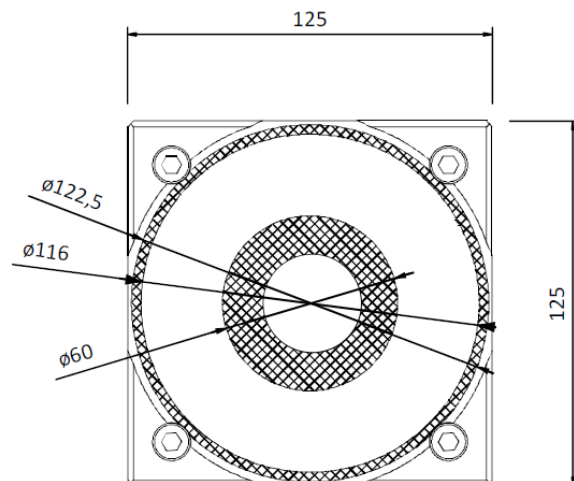

Company • Ixtur Ltd. is a Finnish magnet technology company established in 2010.



PAVLÍNEK
VÁZACÍ PROSTŘEDKY

EMAIL: OBCHOD@PAVLINEK.CZ
TEL: +420 595 693 911
ŠALOUNOVA 746/31, OSTRAVA VÍTKOVICE
IČ: 25358511 DIČ: CZ25358511

